

END SECTIONS FOR HDPE PIPE

Dia.	Gauge	Weight	* A	* H	* L	* W	Slope	Overall Width
6"	18	10	4	3	8	12	2	20"
8"	18	14	5 3/4	4	14 1/2	16	2 1/4	27 1/2"
10"	18	17	7 5/8	6	14 1/2	20	2 1/2	35 1/4"
12"	16	25	7	6	21	24	2 1/2	38"
15"	16	33	8	6	26	30	2 1/2	46"
18"	16	42	8	6	31	36	2 1/2	52"
21"	16	49	9	6	36	42	2 1/2	60"
24"	16	65	10	6	41	48	2 1/2	68"
30"	14	123	12	8	51	60	2 1/2	84"
36"	14	135	14	9	60	72	2 1/2	100"
42"	12	320	16	11	69	84	2 1/2	116"
48"	12	375	18	12	78	90	2 1/4	126"
54"	12	440	18	12	84	102	2 1/4	138"
60"	12/10	610	18	12	87	114	2	150"

Toe plate extensions where specified, to be punched to match holes in apron lip. 3/8" bolts to be furnished. The length of toe plate to be as follows: W + 10" for 12" to 30" diameter pipes inclusive. W + 20" for 36" to 60" diameter pipes inclusive.

Multiple panel end sections shall have lap seams which are to be tightly jointed by bolts. Corner plate, and toe plate to be same gauge as end section.

* - Dimensions in Inches Plus or Minus Standard Shop Tolerance.

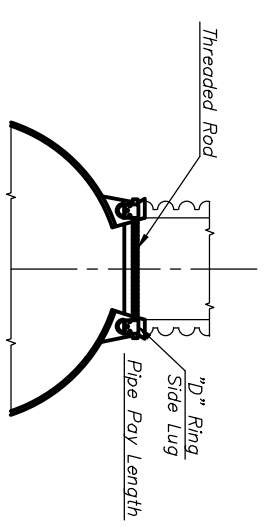

TYPE 2 CONNECTIONS
(12" & Larger)

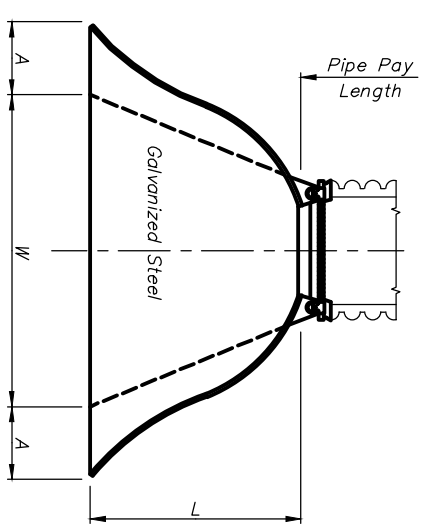

PLAN

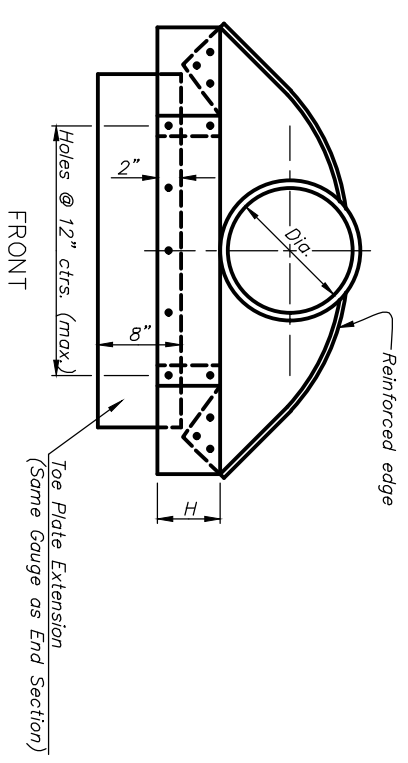

FRONT

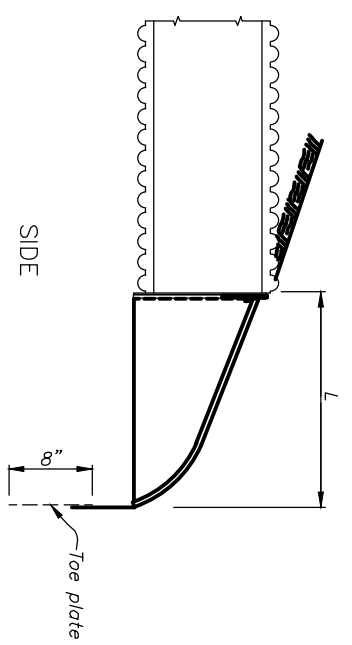

SIDE

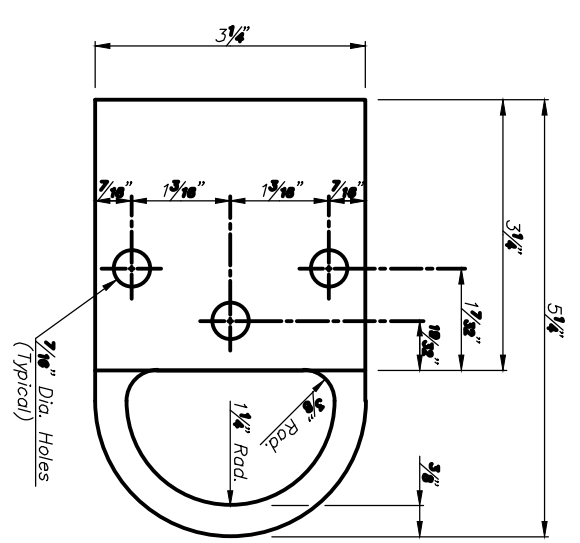

TOP VIEW

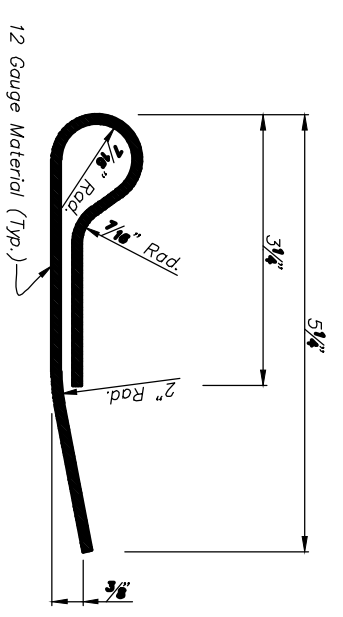

SIDE VIEW

"D" RING SIDE LUG
TYPE 2 ATTACHMENT DETAILS

No.	Date	Revisions

STANDARD END SECTION
FOR HDPE PIPES