

# 1-0 SPECIFICATIONS

## TABLE OF CONTENTS

ADS N-12 <sup>®</sup> ST IB PIPE (ASTM F2648) SPECIFICATION.....	1-3
ADS N-12 <sup>®</sup> WT IB PIPE (PER ASTM F2648) SPECIFICATION .....	1-4
ADS N-12 <sup>®</sup> ST IB PIPE (PER AASHTO) SPECIFICATION .....	1-5
ADS N-12 <sup>®</sup> WT IB PIPE (PER AASHTO) SPECIFICATION .....	1-6
ADS N-12 <sup>®</sup> MEGA GREEN <sup>™</sup> ST IB PIPE SPECIFICATION .....	1-7
ADS N-12 <sup>®</sup> MEGA GREEN <sup>™</sup> WT IB PIPE SPECIFICATION .....	1-8
ADS N-12 <sup>®</sup> WT SERIES 35 PIPE SPECIFICATION .....	1-9
ADS N-12 <sup>®</sup> PLAIN END PIPE (PER ASTM F2648) SPECIFICATION .....	1-10
ADS N-12 <sup>®</sup> PLAIN END PIPE (PER AASHTO) SPECIFICATION .....	1-11
ADS N-12 <sup>®</sup> MEGA GREEN PLAIN END PIPE SPECIFICATION.....	1-12
ADS NEWLINER <sup>®</sup> PIPE SPECIFICATION .....	1-13
ADS RETENTION/DETENTION PIPE SYSTEM SPECIFICATION .....	1-14
ADS HP STORM 12"- 60" PIPE SPECIFICATION .....	1-16
ADS SANITITE <sup>®</sup> HP 12"- 60" PIPE SPECIFICATION .....	1-17
ADS HPXR 75 PIPE SPECIFICATION.....	1-18
ADS N-12 <sup>®</sup> LOW HEAD PIPE SPECIFICATION .....	1-19
ADS SINGLE WALL HEAVY DUTY PIPE SPECIFICATION.....	1-20
ADS SINGLE WALL HIGHWAY PIPE SPECIFICATION .....	1-21
ADS GRAIN-AIRE <sup>®</sup> PIPE SPECIFICATION.....	1-22
ADS ADVANEDGE <sup>®</sup> PIPE SPECIFICATION .....	1-23
ADS SB2 <sup>®</sup> PIPE SPECIFICATION .....	1-24
ADS 3000 TRIPLEWALL <sup>®</sup> PIPE SPECIFICATION.....	1-25
ADS SMOOTHWALL SEWER & DRAIN PIPE SPECIFICATIONS.....	1-26
ADS CHANNEL-FLOW <sup>®</sup> PIPE SPECIFICATIONS.....	1-27
ADS CHANNEL-MUCK PIPE SPECIFICATIONS .....	1-28
ADS DURASLOT <sup>®</sup> PIPE SPECIFICATION .....	1-29
ADS POST TENSIONING DUCT SPECIFICATION.....	1-31
ADS TURF-FLOW PIPE SPECIFICATION.....	1-32
ADS INJECTION MOLDED FITTING SPECIFICATION .....	1-33
MAR MAC <sup>®</sup> POLYSEAL REPAIR COUPLER SPECIFICATION.....	1-35
ADS PVC COUPLING SPECIFICATION.....	1-36
ADS WATERSTOP <sup>™</sup> GASKET SPECIFICATION .....	1-37
ADS FLARED END SECTION SPECIFICATION .....	1-38
ADS MITERED END SECTION SPECIFICATION .....	1-39

ADS TAYLOR END PLUG PRODUCT SPECIFICATION..... 1-40

ADS STORM WATER QUALITY UNIT PRODUCT SPECIFICATION..... 1-41

ADS GREASE INTERCEPTOR PRODUCT SPECIFICATION..... 1-43

ADS BIODIFFUSER™ SEPTIC LEACHING CHAMBER SPECIFICATION ..... 1-45

ADS ARC™ SEPTIC LEACHING CHAMBER SPECIFICATIONS..... 1-47

ADS SUMP PUMP WELL SPECIFICATION..... 1-48

ADS RADON DUAL PURPOSE VENTED SUMP SPECIFICATION ..... 1-49

ADS SEWAGE EJECTOR SUMP SPECIFICATION ..... 1-50

ADS METER PIT SPECIFICATION ..... 1-51

ADS FILTER SOCK SPECIFICATION ..... 1-52

## ADS N-12<sup>®</sup> ST IB PIPE (ASTM F2648) SPECIFICATION

### Scope

This specification describes 4- through 60-inch (100 to 1500 mm) ADS N-12 ST IB pipe (per ASTM F2648) for use in gravity-flow land drainage applications.

### Pipe Requirements

ADS N-12 ST IB pipe (per ASTM F2648) shall have a smooth interior and annular exterior corrugations.

- 4- through 60-inch (100 to 1500 mm) pipe shall meet ASTM F2648.
- Manning's "n" value for use in design shall be 0.012.

### Joint Performance

Pipe shall be joined using a bell & spigot joint meeting ASTM F2648. The joint shall be soil-tight and gaskets for diameters 12- through 60-inch, shall meet the requirements of ASTM F477. For diameters 4- through 10-inch, the joint shall be soil-tight using an engaging dimple connection. Gaskets shall be installed by the pipe manufacturer and covered with a removable, protective wrap to ensure the gasket is free from debris. A joint lubricant available from the manufacturer shall be used on the gasket and bell during assembly.

### Fittings

Fittings shall conform to ASTM F2306. Bell and spigot connections shall utilize a spun-on or welded bell and valley or saddle gasket meeting the soil-tight joint performance requirements of ASTM F2306.

### Material Properties

Material for pipe production shall be an engineered compound of virgin and recycled high density polyethylene conforming with the minimum requirements of cell classification 424420C (ESCR Test Condition B) for 4- through 10-inch (100 to 250 mm) diameters, and 435420C (ESCR Test Condition B) for 12- through 60-inch (300 to 1500 mm) diameters, as defined and described in the latest version of ASTM D3350, except that carbon black content should not exceed 4%. The design engineer shall verify compatibility with overall system including structural, hydraulic, material, and installation requirements for a given application.

### Installation

Installation shall be in accordance with ASTM D2321 and ADS recommended installation guidelines, with the exception that minimum cover in trafficked areas for 4- through 48-inch (100 to 1200 mm) diameters shall be one foot. (0.3 m) and for 60-inch (1500 mm) diameter the minimum cover shall be 2 ft. (0.6 m) in single run applications. Backfill for minimum cover situations shall consist of Class 1 (compacted) or Class 2 (minimum 90% SPD) material. Maximum fill heights depend on embedment material and compaction level; please refer to Technical Note 2.02. Contact your local ADS representative or visit our website at [www.ads-pipe.com](http://www.ads-pipe.com) for a copy of the latest installation guidelines.

### Pipe Dimensions

	Nominal Diameter, in (mm)												
Pipe I.D. in (mm)	4 (100)	6 (150)	8 (200)	10 (250)	12 (300)	15 (375)	18 (450)	24 (600)	30 (750)	36 (900)	42 (1050)	48 (1200)	60 (1500)
Pipe O.D.* in (mm)	4.8 (122)	6.9 (175)	9.1 (231)	11.4 (290)	14.5 (368)	18 (457)	22 (559)	28 (711)	36 (914)	42 (1067)	48 (1219)	54 (1372)	67 (1702)

\*Pipe O.D. values are provided for reference purposes only, values stated for 12 through 60-inch are  $\pm 1$  inch. Contact a sales representative for exact values

\*\*All diameters available with or without perforations.

## ADS N-12® WT IB PIPE (PER ASTM F2648) SPECIFICATION

### Scope

This specification describes 4- through 60-inch (100 to 1500 mm) ADS N-12 WT IB pipe (per ASTM F2648) for use in gravity-flow land drainage applications.

### Pipe Requirements

ADS N-12 WT IB pipe (per ASTM F2648) shall have a smooth interior and annular exterior corrugations.

- 4- through 60-inch (100 to 1500 mm) pipe shall meet ASTM F2648.
- Manning’s “n” value for use in design shall be 0.012.

### Joint Performance

Pipe shall be joined using a bell & spigot joint meeting ASTM F2648. The joint shall be watertight according to the requirements of ASTM D3212. Gaskets shall meet the requirements of ASTM F477. Gaskets shall be installed by the pipe manufacturer and covered with a removable, protective wrap to ensure the gasket is free from debris. A joint lubricant available from the manufacturer shall be used on the gasket and bell during assembly. 12- through 60-inch (300 to 1500 mm) diameters shall have an exterior bell wrap installed by the manufacturer.

### Fittings

Fittings shall conform to ASTM F2306. Bell and spigot connections shall utilize a spun-on or welded bell and valley or saddle gasket meeting the watertight joint performance requirements of ASTM F2306.

### Field Pipe and Joint Performance

To assure watertightness, field performance verification may be accomplished by testing in accordance with ASTM F2487. Appropriate safety precautions must be used when field-testing any pipe material. Contact the manufacturer for recommended leakage rates.

### Material Properties

Material for pipe production shall be an engineered compound of virgin and recycled high-density polyethylene conforming with the minimum requirements of cell classification 424420C (ESCR Test Condition B) for 4- through 10-inch (100 to 250 mm) diameters, and 435420C (ESCR Test Condition B) for 12- through 60-inch (300 to 1500 mm) diameters, as defined and described in the latest version of ASTM D3350, except that carbon black content should not exceed 4%. The design engineer shall verify compatibility with overall system including structural, hydraulic, material, and installation requirements for a given application.

### Installation

Installation shall be in accordance with ASTM D2321 and ADS recommended installation guidelines, with the exception that minimum cover in trafficked areas for 4- through 48-inch (100 to 1200 mm) diameters shall be one foot (0.3 m) and for 60-inch (1500 mm) diameter the minimum cover shall be 2 ft. (0.6 m) in single run applications. Backfill for minimum cover situations shall consist of Class 1 (compacted) or Class 2 (minimum 90% SPD) material. Maximum fill heights depend on embedment material and compaction level; please refer to Technical Note 2.02. Contact your local ADS representative or visit our website at [www.ads-pipe.com](http://www.ads-pipe.com) for a copy of the latest installation guidelines.

### Pipe Dimensions

	Nominal Diameter, in (mm)												
Pipe I.D. in (mm)	4 (100)	6 (150)	8 (200)	10 (250)	12 (300)	15 (375)	18 (450)	24 (600)	30 (750)	36 (900)	42 (1050)	48 (1200)	60 (1500)
Pipe O.D.* in (mm)	4.8 (122)	6.9 (175)	9.1 (231)	11.4 (290)	14.5 (368)	18 (457)	22 (559)	28 (711)	36 (914)	42 (1067)	48 (1219)	54 (1372)	67 (1702)

\*Pipe O.D. values are provided for reference purposes only, values stated for 12 through 60-inch are ±1 inch. Contact a sales representative for exact values

## ADS N-12<sup>®</sup> ST IB PIPE (PER AASHTO) SPECIFICATION

### Scope

This specification describes 4- through 60-inch (100 to 1500 mm) ADS N-12 ST IB pipe (per AASHTO) for use in gravity-flow land drainage applications.

### Pipe Requirements

ADS N-12 ST IB pipe (per AASHTO) shall have a smooth interior and annular exterior corrugations.

- 4- through 10-inch (100 to 250 mm) pipe shall meet AASHTO M252, Type S or SP.
- 12- through 60-inch (300 to 1500 mm) pipe shall meet AASHTO M294, Type S or SP, or ASTM F2306.
- Manning's "n" value for use in design shall be 0.012.

### Joint Performance

Pipe shall be joined using a bell & spigot joint meeting the requirements of AASHTO M252, AASHTO M294, or ASTM F2306. The joint shall be soil-tight and gaskets for diameters 12- through 60-inch, shall meet the requirements of ASTM F477. For diameters 4- through 10-inch, the joint shall be soil-tight using an engaging dimple connection. Gaskets shall be installed by the pipe manufacturer and covered with a removable, protective wrap to ensure the gasket is free from debris. A joint lubricant available from the manufacturer shall be used on the gasket and bell during assembly.

### Fittings

Fittings shall conform to AASHTO M252, AASHTO M294, or ASTM F2306. Bell and spigot connections shall utilize a spun-on or welded bell and valley or saddle gasket meeting the soil-tight joint performance requirements of AASHTO M252, AASHTO M294, or ASTM F2306.

### Material Properties

Virgin material for pipe and fitting production shall be high density polyethylene conforming with the minimum requirements of cell classification 424420C for 4- through 10-inch (100 to 250 mm) diameters, and 435400C for 12- through 60-inch (300 to 1500 mm) diameters, as defined and described in the latest version of ASTM D3350, except that carbon black content should not exceed 4%. The 12- through 60-inch (300 to 1500 mm) virgin pipe material shall comply with the notched constant ligament-stress (NCLS) test as specified in Sections 9.5 and 5.1 of AASHTO M294 and ASTM F2306, respectively.

### Installation

Installation shall be in accordance with ASTM D2321 and ADS recommended installation guidelines, with the exception that minimum cover in trafficked areas for 4- through 48-inch (100 to 1200 mm) diameters shall be one foot. (0.3 m) and for 60-inch (1500 mm) diameter the minimum cover shall be 2 ft. (0.6 m) in single run applications. Backfill for minimum cover situations shall consist of Class 1 (compacted), Class 2 (minimum 90% SPD) or Class 3 (minimum 95% SPD) material. Maximum fill heights depend on embedment material and compaction level; please refer to Technical Note 2.01. Contact your local ADS representative or visit our website at [www.ads-pipe.com](http://www.ads-pipe.com) for a copy of the latest installation guidelines.

### Pipe Dimensions

	Nominal Diameter, in (mm)												
Pipe I.D. in (mm)	4 (100)	6 (150)	8 (200)	10 (250)	12 (300)	15 (375)	18 (450)	24 (600)	30 (750)	36 (900)	42 (1050)	48 (1200)	60 (1500)
Pipe O.D.* in (mm)	4.8 (122)	6.9 (175)	9.1 (231)	11.4 (290)	14.5 (368)	18 (457)	22 (559)	28 (711)	36 (914)	42 (1067)	48 (1219)	54 (1372)	67 (1702)

\*Pipe O.D. values are provided for reference purposes only, values stated for 12 through 60-inch are ±1 inch. Contact a sales representative for exact values

\*\*All diameters available with or without perforations.

## ADS N-12<sup>®</sup> WT IB PIPE (PER AASHTO) SPECIFICATION

### Scope

This specification describes 4- through 60-inch (100 to 1500 mm) ADS N-12 WT IB pipe (per AASHTO) for use in gravity-flow land drainage applications.

### Pipe Requirements

ADS N-12 WT IB pipe (per AASHTO) shall have a smooth interior and annular exterior corrugations.

- 4- through 10-inch (100 to 250 mm) pipe shall meet AASHTO M252, Type S.
- 12- through 60-inch (300 to 1500 mm) pipe shall meet AASHTO M294, Type S or ASTM F2306.
- Manning’s “n” value for use in design shall be 0.012.

### Joint Performance

Pipe shall be joined using a bell & spigot joint meeting the requirements of AASHTO M252, AASHTO M294, or ASTM F2306. The joint shall be watertight according to the requirements of ASTM D3212. Gaskets shall meet the requirements of ASTM F477. Gaskets shall be installed by the pipe manufacturer and covered with a removable, protective wrap to ensure the gasket is free from debris. A joint lubricant available from the manufacturer shall be used on the gasket and bell during assembly. 12- through 60-inch (300 to 1500 mm) diameters shall have an exterior bell wrap installed by the manufacturer.

### Fittings

Fittings shall conform to AASHTO M252, AASHTO M294, or ASTM F2306. Bell and spigot connections shall utilize a spun-on or welded bell and valley or saddle gasket meeting the watertight joint performance requirements of AASHTO M252, AASHTO M294, or ASTM F2306.

### Field Pipe and Joint Performance

To assure watertightness, field performance verification may be accomplished by testing in accordance with ASTM F2487. Appropriate safety precautions must be used when field-testing any pipe material. Contact the manufacturer for recommended leakage rates.

### Material Properties

Virgin material for pipe and fitting production shall be high-density polyethylene conforming with the minimum requirements of cell classification 424420C for 4- through 10-inch (100 to 250 mm) diameters, and 435400C for 12- through 60-inch (300 to 1500 mm) diameters, as defined and described in the latest version of ASTM D3350, except that carbon black content should not exceed 4%. The 12- through 60-inch (300 to 1500 mm) virgin pipe material shall comply with the notched constant ligament-stress (NCLS) test as specified in Sections 9.5 and 5.1 of AASHTO M294 and ASTM F2306 respectively.

### Installation

Installation shall be in accordance with ASTM D2321 and ADS recommended installation guidelines, with the exception that minimum cover in trafficked areas for 4- through 48-inch (100 to 1200 mm) diameters shall be one foot. (0.3 m) and for 60-inch (1500 mm) diameter the minimum cover shall be 2 ft. (0.6 m) in single run applications. Backfill for minimum cover situations shall consist of Class 1 (compacted), Class 2 (minimum 90% SPD) or Class 3 (minimum 95%) material. Maximum fill heights depend on embedment material and compaction level; please refer to Technical Note 2.01. Contact your local ADS representative or visit our website at [www.ads-pipe.com](http://www.ads-pipe.com) for a copy of the latest installation guidelines.

### Pipe Dimensions

	Nominal Diameter, in (mm)												
Pipe I.D. in (mm)	4 (100)	6 (150)	8 (200)	10 (250)	12 (300)	15 (375)	18 (450)	24 (600)	30 (750)	36 (900)	42 (1050)	48 (1200)	60 (1500)
Pipe O.D.* in (mm)	4.8 (122)	6.9 (175)	9.1 (231)	11.4 (290)	14.5 (368)	18 (457)	22 (559)	28 (711)	36 (914)	42 (1067)	48 (1219)	54 (1372)	67 (1702)

\*Pipe O.D. values are provided for reference purposes only, values stated for 12 through 60-inch are ±1 inch. Contact a sales representative for exact values

## ADS N-12<sup>®</sup> MEGA GREEN<sup>™</sup> ST IB PIPE SPECIFICATION

### Scope

This specification describes 4- through 60-inch (100 to 1500 mm) ADS N-12 MEGA GREEN<sup>™</sup> ST IB pipe for use in gravity-flow land drainage applications.

### Pipe Requirements

ADS N-12 MEGA GREEN ST IB pipe shall have a smooth interior and annular exterior corrugations.

- 4- through 60-inch (100 to 1500 mm) pipe shall meet ASTM F2648.
- Manning's "n" value for use in design shall be 0.012.

### Joint Performance

Pipe shall be joined using a bell & spigot joint meeting ASTM F2648. The joint shall be soil-tight and gaskets for diameters 12- through 60-inch, shall meet the requirements of ASTM F477. For diameters 4- through 10-inch, the joint shall be soil-tight using an engaging dimple connection. Gaskets shall be installed by the pipe manufacturer and covered with a removable, protective wrap to ensure the gasket is free from debris. A joint lubricant available from the manufacturer shall be used on the gasket and bell during assembly.

### Fittings

Fittings shall conform to ASTM F2306. Bell and spigot connections shall utilize a spun-on or welded bell and valley or saddle gasket meeting the soil-tight joint performance requirements of ASTM F2306.

### Material Properties

Material for pipe production shall be an engineered compound of virgin and recycled high density polyethylene conforming with the minimum requirements of cell classification 424420C (ESCR Test Condition B) for 4- through 10-inch (100 to 250 mm) diameters, and 435420C (ESCR Test Condition B) for 12- through 60-inch (300 to 1500 mm) diameters, as defined and described in the latest version of ASTM D3350, except that carbon black content should not exceed 4%. The design engineer shall verify compatibility with overall system including structural, hydraulic, material, and installation requirements for a given application.

### Installation

Installation shall be in accordance with ASTM D2321 and ADS recommended installation guidelines, with the exception that minimum cover in trafficked areas for 4- through 48-inch (100 to 1200 mm) diameters shall be one foot. (0.3 m) and for 60-inch (1500 mm) diameter the minimum cover shall be 2 ft. (0.6 m) in single run applications. Backfill for minimum cover situations shall consist of Class 1 (compacted) or Class 2 (minimum 90% SPD) material. Maximum fill heights depend on embedment material and compaction level; please refer to Technical Note 2.02. Contact your local ADS representative or visit our website at [www.ads-pipe.com](http://www.ads-pipe.com) for a copy of the latest installation guidelines.

### Pipe Dimensions

	Nominal Diameter, in (mm)												
Pipe I.D. in (mm)	4 (100)	6 (150)	8 (200)	10 (250)	12 (300)	15 (375)	18 (450)	24 (600)	30 (750)	36 (900)	42 (1050)	48 (1200)	60 (1500)
Pipe O.D.* in (mm)	4.8 (122)	6.9 (175)	9.1 (231)	11.4 (290)	14.5 (368)	18 (457)	22 (559)	28 (711)	36 (914)	42 (1067)	48 (1219)	54 (1372)	67 (1702)

\*Pipe O.D. values are provided for reference purposes only, values stated for 12 through 60-inch are ±1 inch. Contact a sales representative for exact values

\*\*All diameters available with or without perforations.



## ADS N-12<sup>®</sup> MEGA GREEN<sup>™</sup> WT IB PIPE SPECIFICATION

### Scope

This specification describes 4- through 60-inch (100 to 1500 mm) ADS N-12 MEGA GREEN<sup>™</sup> WT IB pipe for use in gravity-flow land drainage applications.

### Pipe Requirements

ADS N-12 MEGA GREEN WT IB pipe shall have a smooth interior and annular exterior corrugations.

- 4- through 60-inch (100 to 1500 mm) pipe shall meet ASTM F2648.
- Manning’s “n” value for use in design shall be 0.012.

### Joint Performance

Pipe shall be joined using a bell & spigot joint meeting ASTM F2648. The joint shall be watertight according to the requirements of ASTM D3212. Gaskets shall meet the requirements of ASTM F477. Gaskets shall be installed by the pipe manufacturer and covered with a removable, protective wrap to ensure the gasket is free from debris. A joint lubricant available from the manufacturer shall be used on the gasket and bell during assembly. 12- through 60-inch (300 to 1500 mm) diameters shall have an exterior bell wrap installed by the manufacturer.

### Fittings

Fittings shall conform to ASTM F2306. Bell and spigot connections shall utilize a spun-on or welded bell and valley or saddle gasket meeting the watertight joint performance requirements of ASTM F2306.

### Field Pipe and Joint Performance

To assure watertightness, field performance verification may be accomplished by testing in accordance with ASTM F2487. Appropriate safety precautions must be used when field-testing any pipe material. Contact the manufacturer for recommended leakage rates.

### Material Properties

Material for pipe production shall be an engineered compound of virgin and recycled high density polyethylene conforming with the minimum requirements of cell classification 424420C (ESCR Test Condition B) for 4- through 10-inch (100 to 250 mm) diameters, and 435420C (ESCR Test Condition B) for 12- through 60-inch (300 to 1500 mm) diameters, as defined and described in the latest version of ASTM D3350, except that carbon black content should not exceed 4%. The design engineer shall verify compatibility with overall system including structural, hydraulic, material, and installation requirements for a given application.

### Installation

Installation shall be in accordance with ASTM D2321 and ADS recommended installation guidelines, with the exception that minimum cover in trafficked areas for 4- through 48-inch (100 to 1200 mm) diameters shall be one foot. (0.3 m) and for 60-inch (1500 mm) diameter the minimum cover shall be 2 ft. (0.6 m) in single run applications. Backfill for minimum cover situations shall consist of Class 1 (compacted) or Class 2 (minimum 90% SPD) material. Maximum fill heights depend on embedment material and compaction level; please refer to Technical Note 2.02. Contact your local ADS representative or visit our website at [www.ads-pipe.com](http://www.ads-pipe.com) for a copy of the latest installation guidelines.

### Pipe Dimensions

	Nominal Diameter, in (mm)												
Pipe I.D. in (mm)	4 (100)	6 (150)	8 (200)	10 (250)	12 (300)	15 (375)	18 (450)	24 (600)	30 (750)	36 (900)	42 (1050)	48 (1200)	60 (1500)
Pipe O.D.* in (mm)	4.8 (122)	6.9 (175)	9.1 (231)	11.4 (290)	14.5 (368)	18 (457)	22 (559)	28 (711)	36 (914)	42 (1067)	48 (1219)	54 (1372)	67 (1702)

\*Pipe O.D. values are provided for reference purposes only, values stated for 12 through 60-inch are ±1 inch. Contact a sales representative for exact values



## ADS N-12<sup>®</sup> WT SERIES 35 PIPE SPECIFICATION

### Scope

This specification describes 4- through 24-inch (100 to 600 mm) ADS N-12 WT Series 35 pipe for use in gravity-flow land drainage applications.

### Pipe Requirements

N-12 WT Series 35 pipe shall have a smooth interior and annular exterior corrugations.

- 4- through 10-inch (100 to 250 mm) pipe shall meet AASHTO M252, Type S.
- 12- through 24-inch (300 to 600 mm) pipe shall meet AASHTO M294, Type S or ASTM F2306.
- Manning's "n" value for use in design shall be 0.012.

### Joint Performance

Pipe shall be joined with the N-12 WT Series 35 joint meeting the requirements of AASHTO M252, AASHTO M294 or ASTM F2306. The joint shall be watertight according to the requirements of ASTM D3212. Gaskets shall meet the requirements of ASTM F477. Gaskets shall be installed by the pipe manufacturer and covered with a removable, protective wrap to ensure the gasket is free from debris. A joint lubricant available from the manufacturer shall be used on the gasket and bell during assembly.

Bells shall be bell-bell couplers manufactured from PVC. Bell-bell couplers shall be installed on one side by the manufacturer.

### Fittings

Fittings shall conform to AASHTO M252, AASHTO M294, or ASTM F2306. Joint connections shall utilize a PVC bell-bell coupler and valley gasket meeting the watertight joint performance requirements of AASHTO M252, AASHTO M294, or ASTM F2306.

### Material Properties

Virgin material for pipe and fitting production shall be high-density polyethylene conforming with the minimum requirements of cell classification 424420C for 4- through 10-inch (100 to 250 mm) diameters, and 435400C for 12- through 24-inch (300 to 600 mm) diameters, as defined and described in the latest version of ASTM D3350, except that carbon black content should not exceed 4%. The 12- through 24-inch (300 to 600 mm) virgin pipe material shall comply with the notched constant ligament-stress (NCLS) test as specified in Sections 9.5 and 5.1 of AASHTO M294 and ASTM F2306 respectively.

Bells shall be manufactured from PVC pipe stock, utilizing a thermo-molding process to reform the pipe stock to the specified coupler. The pipe stock used to manufacture the bell-bell coupler shall meet the performance requirements for fabricated fittings as specified in ASTM D3034.

### Installation

Installation shall be in accordance with ASTM D2321 and ADS recommended installation guidelines, with the exception that minimum cover in trafficked areas for 4- through 24-inch (100 to 600 mm) diameters shall be one foot (0.3 m) in single run applications. Backfill for minimum cover situations shall consist of Class 1 (compacted), Class 2 (minimum 90% SPD), or Class 3 (minimum 95%) material. Maximum fill heights depend on embedment material and compaction level; please refer to Technical Note 2.01. Contact your local ADS representative or visit our website at [www.ads-pipe.com](http://www.ads-pipe.com) for a copy of the latest installation guidelines.

### Pipe Dimensions

	Nominal Diameter, in (mm)							
Pipe I.D. in (mm)	4 (100)	6 (150)	8 (200)	10 (250)	12 (300)	15 (375)	18 (450)	24 (600)
Pipe O.D.* in (mm)	4.8 (122)	6.9 (175)	9.1 (231)	11.4 (290)	14.5 (368)	18 (457)	22 (559)	28 (711)

\*Pipe O.D. values are provided for reference purposes only, values stated for 12 through 60-inch are ±1 inch. Contact a sales representative for exact values

## ADS N-12<sup>®</sup> PLAIN END PIPE (PER ASTM F2648) SPECIFICATION

### Scope

This specification describes 4- through 60-inch (100 to 1500 mm) ADS N-12 plain end pipe (per ASTM F2648) for use in gravity-flow land drainage applications.

### Pipe Requirements

ADS N-12 plain end pipe (per ASTM F2648) shall have a smooth interior and annular exterior corrugations.

- 4- through 60-inch (100 to 1500 mm) pipe shall meet ASTM F2648.
- Manning’s “n” value for use in design shall be 0.012.

### Joint Performance

Pipe shall be joined with coupling bands covering at least two full corrugations on each end of the pipe. Standard connections shall meet or exceed the soil-tight requirements of ASTM F2648.

Gasketed connections shall incorporate a closed-cell synthetic expanded rubber gasket meeting the requirements of ASTM D1056 Grade 2A2. Gaskets, when applicable, shall be installed by the pipe manufacturer.

### Fittings

Fittings shall conform to ASTM F2306.

### Material Properties

Material for pipe production shall be an engineered compound of virgin and recycled high density polyethylene conforming with the minimum requirements of cell classification 424420C (ESCR Test Condition B) for 4- through 10-inch (100 to 250 mm) diameters, and 435420C (ESCR Test Condition B) for 12- through 60-inch (300 to 1500 mm) diameters, as defined and described in the latest version of ASTM D3350, except that carbon black content should not exceed 4%. The design engineer shall verify compatibility with overall system including structural, hydraulic, material, and installation requirements for a given application.

### Installation

Installation shall be in accordance with ASTM D2321 and ADS recommended installation guidelines, with the exception that minimum cover in trafficked areas for 4- through 48-inch (100 to 1200 mm) diameters shall be one foot (0.3 m) and for 60-inch (1500 mm) diameter the minimum cover shall be 2 ft. (0.6 m) in single run applications. Backfill for minimum cover situations shall consist of Class 1 (compacted) or Class 2 (minimum 90% SPD) material. Maximum fill heights depend on embedment material and compaction level; please refer to Technical Note 2.02. Contact your local ADS representative or visit our website at [www.ads-pipe.com](http://www.ads-pipe.com) for a copy of the latest installation guidelines.

### Pipe Dimensions

	Nominal Diameter, in (mm)												
Pipe I.D. in (mm)	4 (100)	6 (150)	8 (200)	10 (250)	12 (300)	15 (375)	18 (450)	24 (600)	30 (750)	36 (900)	42 (1050)	48 (1200)	60 (1500)
Pipe O.D.* in (mm)	4.8 (122)	6.9 (175)	9.1 (231)	11.4 (290)	14.5 (368)	18 (457)	22 (559)	28 (711)	36 (914)	42 (1067)	48 (1219)	54 (1372)	67 (1702)

\*Pipe O.D. values are provided for reference purposes only, values stated for 12 through 60-inch are ±1 inch. Contact a sales representative for exact values  
 \*\*All diameters available with or without perforations.

## ADS N-12<sup>®</sup> PLAIN END PIPE (PER AASHTO) SPECIFICATION

### Scope

This specification describes 4- through 60-inch (100 to 1500 mm) ADS N-12 plain end pipe (per AASHTO) for use in gravity-flow land drainage applications.

### Pipe Requirements

ADS N-12 plain end pipe (per AASHTO) shall have a smooth interior and annular exterior corrugations.

- 4- through 10-inch (100 to 250 mm) pipe shall meet AASHTO M252, Type S or SP.
- 12- through 60-inch (300 to 1500 mm) pipe shall meet AASHTO M294, Type S or SP, or ASTM F2306.
- Manning’s “n” value for use in design shall be 0.012.

### Joint Performance

Pipe shall be joined with coupling bands covering at least two full corrugations on each end of the pipe. Standard connections shall meet or exceed the soil-tight requirements of AASHTO M252, AASHTO M294, or ASTM F2306.

Gasketed connections shall incorporate a closed-cell synthetic expanded rubber gasket meeting the requirements of ASTM D1056 Grade 2A2. Gaskets, when applicable, shall be installed by the pipe manufacturer.

### Fittings

Fittings shall conform to AASHTO M252, AASHTO M294, or ASTM F2306.

### Material Properties

Virgin material for pipe and fitting production shall be high density polyethylene conforming with the minimum requirements of cell classification 424420C for 4- through 10-inch (100 to 250 mm) diameters, and 435400C for 12- through 60-inch (300 to 1500 mm) diameters, as defined and described in the latest version of ASTM D3350, except that carbon black content should not exceed 4%. The 12- through 60-inch (300 to 1500mm) virgin pipe material shall comply with the notched constant ligament-stress (NCLS) test as specified in Sections 9.5 and 5.1 of AASHTO M294 and ASTM F2306 respectively.

### Installation

Installation shall be in accordance with ASTM D2321 and ADS recommended installation guidelines, with the exception that minimum cover in trafficked areas for 4- through 48-inch (100 to 1200 mm) diameters shall be one foot. (0.3 m) and for 60-inch (1500 mm) diameter the minimum cover shall be 2 ft. (0.6 m) in single run applications. Backfill for minimum cover situations shall consist of Class 1 (compacted), Class 2 (minimum 90% SPD) or Class 3 (minimum 95%) material. Maximum fill heights depend on embedment material and compaction level; please refer to Technical Note 2.01. Contact your local ADS representative or visit our website at [www.ads-pipe.com](http://www.ads-pipe.com) for a copy of the latest installation guidelines.

### Pipe Dimensions

	Nominal Diameter, in (mm)												
Pipe I.D. in (mm)	4 (100)	6 (150)	8 (200)	10 (250)	12 (300)	15 (375)	18 (450)	24 (600)	30 (750)	36 (900)	42 (1050)	48 (1200)	60 (1500)
Pipe O.D.* in (mm)	4.8 (122)	6.9 (175)	9.1 (231)	11.4 (290)	14.5 (368)	18 (457)	22 (559)	28 (711)	36 (914)	42 (1067)	48 (1219)	54 (1372)	67 (1702)

\*Pipe O.D. values are provided for reference purposes only, values stated for 12 through 60-inch are ±1 inch. Contact a sales representative for exact values

\*\*All diameters available with or without perforations.

## ADS N-12<sup>®</sup> MEGA GREEN PLAIN END PIPE SPECIFICATION

### Scope

This specification describes 4- through 60-inch (100 to 1500 mm) ADS N-12 MEGA GREEN<sup>™</sup> plain end pipe for use in gravity-flow land drainage applications.

### Pipe Requirements

ADS N-12 MEGA GREEN plain end pipe shall have a smooth interior and annular exterior corrugations.

- 4- through 60-inch (100 to 1500 mm) pipe shall meet ASTM F2648.
- Manning’s “n” value for use in design shall be 0.012.

### Joint Performance

Pipe shall be joined with coupling bands covering at least two full corrugations on each end of the pipe. Standard connections shall meet or exceed the soil-tight requirements of ASTM F2648.

Gasketed connections shall incorporate a closed-cell synthetic expanded rubber gasket meeting the requirements of ASTM D1056 Grade 2A2. Gaskets, when applicable, shall be installed by the pipe manufacturer.

### Fittings

Fittings shall conform to ASTM F2306.

### Material Properties

Material for pipe production shall be an engineered compound of virgin and recycled high density polyethylene conforming with the minimum requirements of cell classification 424420C (ESCR Test Condition B) for 4- through 10-inch (100 to 250 mm) diameters, and 435420C (ESCR Test Condition B) for 12- through 60-inch (300 to 1500 mm) diameters, as defined and described in the latest version of ASTM D3350, except that carbon black content should not exceed 4%. The design engineer shall verify compatibility with overall system including structural, hydraulic, material, and installation requirements for a given application.

### Installation

Installation shall be in accordance with ASTM D2321 and ADS recommended installation guidelines, with the exception that minimum cover in trafficked areas for 4- through 48-inch (100 to 1200 mm) diameters shall be one foot (0.3 m) and for 60-inch (1500 mm) diameter the minimum cover shall be 2 ft. (0.6 m) in single run applications. Backfill for minimum cover situations shall consist of Class 1 (compacted) or Class 2 (minimum 90% SPD) material. Maximum fill heights depend on embedment material and compaction level; please refer to Technical Note 2.02. Contact your local ADS representative or visit our website at [www.ads-pipe.com](http://www.ads-pipe.com) for a copy of the latest installation guidelines.

### Pipe Dimensions

Nominal Diameter, in (mm)													
Pipe I.D. in (mm)	4 (100)	6 (150)	8 (200)	10 (250)	12 (300)	15 (375)	18 (450)	24 (600)	30 (750)	36 (900)	42 (1050)	48 (1200)	60 (1500)
Pipe O.D.* in (mm)	4.8 (122)	6.9 (175)	9.1 (231)	11.4 (290)	14.5 (368)	18 (457)	22 (559)	28 (711)	36 (914)	42 (1067)	48 (1219)	54 (1372)	67 (1702)

\*Pipe O.D. values are provided for reference purposes only, values stated for 12 through 60-inch are ±1 inch. Contact a sales representative for exact values  
 \*\*All diameters available with or without perforations.

## ADS NEWLINER® PIPE SPECIFICATION

### Scope

This specification describes spiral wound 12-through 60-inch (300 to 1500 mm) NEWLINER HDPE pipe for use in underground culverts, in-place relining, and stormwater management applications.

### Pipe Requirements

NEWLINER pipe shall have a smooth interior and exterior wall

- 12-through 60-inch (300 to 1500 mm) shall meet ASTM F894
- Manning’s “n” value for use in design shall be 0.012

### Joint Performance

Standard connections shall meet or exceed the soil-tight requirements of ASTM F894, unless otherwise noted. Threaded joints available in 12-through 60-inch (300 to 1500 mm). Plain end/welded available in 12-through 72-inch (300 to 1830 mm).

### Material Properties

Virgin Material for pipe production shall be high density polyethylene conforming to the minimum requirements of cell classification 345464C for 12-through 60-inch (300 to 1500 mm) diameters, as defined and described in the latest version of ASTM D3350.

### Installation

Installation shall be in accordance with ASTM D2321 and ADS recommended installation guidelines, with the exception that minimum cover in trafficked areas for 12- through 48-inch (300 to 1200 mm) diameters shall be one foot. (0.3 m), and for 54- through 60-inch (1375 to 1500 mm) diameters the minimum cover shall be 2 ft. (0.6 m). Backfill for minimum cover situations shall consist of Class 1 (compacted), Class 2 (minimum 90% SPD) or Class 3 (minimum 95%) material. Maximum fill heights depend on embedment material and compaction level; please refer to Technical Note 2.10. Contact your local ADS representative for installation guidance.

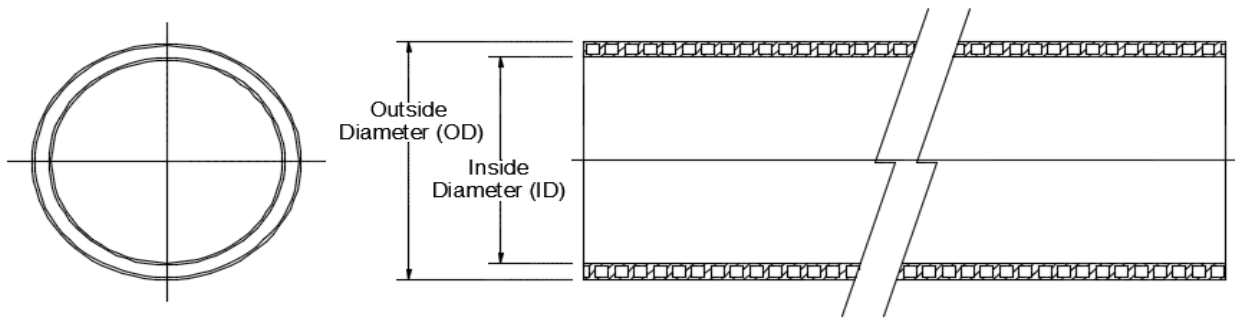

### Pipe Dimensions

Pipe I.D. in (mm)	(12) 300	(15) 380	(18) 460	(19.5) 490	(21) 530	(24) 610	(27) 690	(30) 760	(33) 840	(36) 910	(40) 1020
Pipe O.D. in (mm)	(13.6) 345	(16.9) 430	(20.4) 520	(22.3) 565	(23.8) 605	(27.2) 690	(30.5) 775	(34) 865	(38) 965	(40.5) 1029	(46) 1168
RSC	160	160	160	160	160	160	160	160	160	160	160

Pipe I.D. in (mm)	(42) 1070	(48) 1220	(54) 1370	(60) 1520
Pipe O.D. in (mm)	(48.6) 1234	(54.9) 1394	(61.6) 1564	(68) 1727
RSC	160	160	160	160

## ADS RETENTION/DETENTION PIPE SYSTEM SPECIFICATION

### Scope

This specification describes ADS Retention/Detention Pipe Systems for use in non-pressure gravity-flow storm water collection systems utilizing a continuous outfall structure.

### Pipe Requirements

ADS Retention/Detention systems may utilize any of the various pipe products below:

- N-12<sup>®</sup> ST IB pipe (per AASHTO) shall meet AASHTO M294, Type S or ASTM F2306
- N-12 ST IB pipe (per ASTM F2648) shall meet ASTM F2648
- N-12 MEGA GREEN™ ST IB shall meet ASTM F2648
- N-12 WT IB pipe (per AASHTO) shall meet AASHTO M294, Type S or ASTM F2306
- N-12 WT IB pipe (per ASTM F2648) shall meet ASTM F2648
- N-12 MEGA GREEN™ WT IB shall meet ASTM F2648

All products shall have a smooth interior and annular exterior corrugations. All ST IB pipe products are available as perforated or non-perforated. WT IB pipe products are only available as non-perforated.

Product-specific pipe specifications are available in the Drainage Handbook Section 1 *Specifications*.

### Joint Performance

Plain End/Soil-tight (ST IB)

ST IB pipe shall be joined using a bell & spigot joint. The bell & spigot joint shall meet the soil-tight requirements of ASTM F2306 and gaskets shall meet the requirements of ASTM F477.

Plain End pipe & fittings connections shall be joined with coupling bands covering at least two full corrugations on each end of the pipe. Gasketed soil-tight coupling band connections shall incorporate a closed-cell synthetic expanded rubber gasket meeting the requirements of ASTM D1056 Grade 2A2. Gaskets, when applicable, shall be installed by the pipe manufacturer.

Watertight (WT IB):

WT IB pipe shall be joined using a bell & spigot joint. The joint shall be watertight according to the requirements of ASTM D3212. Gaskets shall meet the requirements of ASTM F477. 12- through 60-inch (300 to 1500 mm) diameters shall have an exterior bell wrap installed by the manufacturer.

Pipe & fitting connections shall be with a bell and spigot connection utilizing a spun-on or welded bell and valley or saddle gasket. The joint shall meet the watertight requirements of ASTM D3212 and gaskets shall meet the requirements of ASTM F477. Detention systems are subject to greater leakage than typical single run storm sewer application and therefore are not appropriate for applications requiring long-term fluid containment or hydrostatic pressure. For additional details refer to Technical Note 7.01 *Rainwater Harvesting with HDPE Cisterns*.

### Fittings

Fittings shall conform to ASTM F2306 and meet joint performance requirements indicated above for fitting connections. Custom fittings are available and may require special installation criterion.

### Installation

Installation shall be in accordance with ASTM D2321 and ADS recommended installation guidelines, with the exception that minimum cover in non-traffic areas for 12- through 60-inch (300 to 1500mm) diameters shall be one foot (0.3m). Minimum cover in trafficked areas for 12- through 36-inch (300 to 900mm) diameters shall be one foot (0.3m) and for 42- through 60-inch (1050 to 1500mm) diameters, the minimum cover shall be two feet (0.6m). Backfill shall consist of Class 1 (compacted) or Class 2 (minimum 90% SPD) material, with the exception that 60-inch fittings shall use Class 1 (compacted) material only. Minimum cover heights do not account for pipe buoyancy. Refer to ADS Technical Note 5.05 HDPE Pipe Flotation for buoyancy design considerations. Maximum cover over system using standard backfill is 8 feet (2.4m); contact a representative when maximum fill height may be exceeded. Additional installation requirements are provided in the Drainage Handbook Section 6 Retention/Detention.

**TYPICAL RETENTION/DETENTION CROSS SECTION**

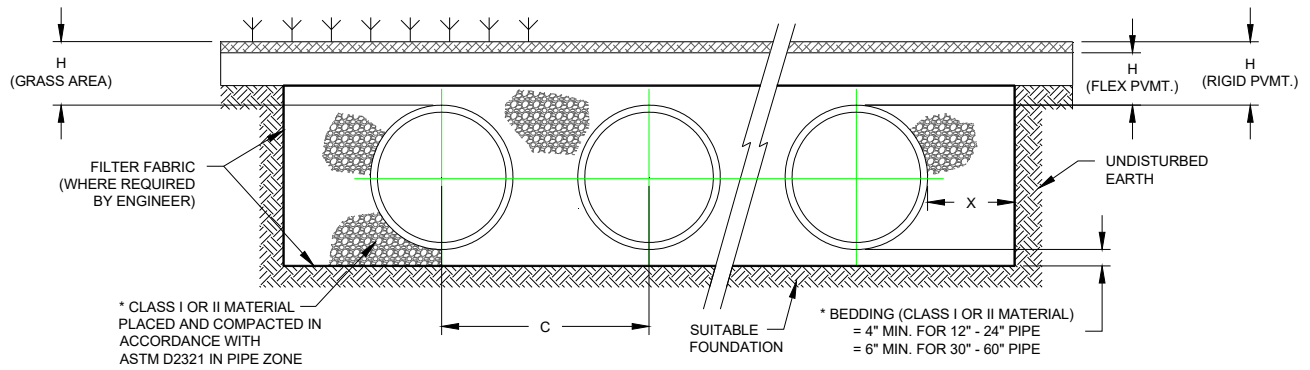

MINIMUM H (GRASS) = 12" FOR 12" THROUGH 60" HDPE PIPE  
 MINIMUM H (FLEX PVMT), H (RIGID PVMT) = 12" FOR UP TO AND INCLUDING 36" HDPE PIPE  
 = 24" FOR 42" THROUGH 60" HDPE PIPE

\* CLASS I BACKFILL REQUIRED AROUND 60" DIAMETER FITTINGS.

MAXIMUM FILL HEIGHT LIMITED TO 8-FT OVER FITTINGS FOR STANDARD INSTALLATIONS. CONTACT REPRESENTATIVE WHEN MAXIMUM FILL HEIGHTS EXCEED 8-FT FOR INSTALLATION CONSIDERATIONS.

**ADDITIONAL REFERENCES**

Drainage Handbook Section 6 *Retention/Detention*

Technical Note 6.01 *Retention/Detention System Maintenance*

Technical Note 7.01 *Rainwater Harvesting with HDPE Pipe*

Standard Detail 701 *Retention-Detention System (Plan View)*

Standard Detail 702 *Retention-Detention System (Cross-Section)*

Standard Detail 703 *Retention-Detention System (Riser & Cleanout)*

Standard Detail 704 *Flowable Fill Installation (Nyloplast Riser)*

All references are available for download at [www.ads-pipe.com](http://www.ads-pipe.com)



## ADS HP STORM 12”- 60” PIPE SPECIFICATION

### Scope

This specification describes 12- through 60-inch (300 to 1500 mm) ADS HP Storm pipe for use in gravity-flow storm drainage applications.

### Pipe Requirements

ADS HP Storm pipe shall have a smooth interior and annular exterior corrugations.

- 12- through 60-inch (300 to 1500 mm) pipe shall meet ASTM F2881 or AASHTO M330
- Manning’s “n” value for use in design shall be 0.012

### Joint Performance

Pipe shall be joined using a bell & spigot joint meeting the requirements of ASTM F2881 or AASHTO M330. The joint shall be watertight according to the requirements of ASTM D3212. Gaskets shall meet the requirements of ASTM F477. Gasket shall be installed by the pipe manufacturer and covered with a removable, protective wrap to ensure the gasket is free from debris. A joint lubricant available from the manufacturer shall be used on the gasket and bell during assembly. 12- through 60-inch (300 to 1500 mm) diameters shall have an exterior bell wrap installed by the manufacturer.

### Fittings

Fittings shall conform to ASTM F2881 or AASHTO M330. Bell and spigot connections shall utilize a welded or integral bell and valley or inline gaskets meeting the watertight joint performance requirements of ASTM D3212.

### Field Pipe and Joint Performance

To assure watertightness, field performance verification may be accomplished by testing in accordance with ASTM F1417 or ASTM F2487. Appropriate safety precautions must be used when field-testing any pipe material. Contact the manufacturer for recommended leakage rates.

### Material Properties

Polypropylene compound for pipe and fitting production shall be impact modified copolymer meeting the material requirements of ASTM F2881, Section 5 and AASHTO M330, Section 6.1.

### Installation

Installation shall be in accordance with ASTM D2321 and ADS recommended installation guidelines, with the exception that minimum cover in traffic areas for 12- through 48-inch (300 to 1200 mm) diameters shall be one foot (0.3 m) and for 60-inch (1500 mm) diameter the minimum cover shall be 2 ft. (0.6 m) in single run applications. Backfill for minimum cover situations shall consist of Class 1 (compacted), Class 2 (minimum 90% SPD), or Class 3 (minimum 95%) material. Maximum fill heights depend on embedment material and compaction level; please refer to Technical Note 2.04. Contact your local ADS representative or visit our website at [www.ads-pipe.com](http://www.ads-pipe.com) for a copy of the latest installation guidelines.

### Pipe Dimensions

Nominal Pipe I.D. in (mm)	12 (300)	15 (375)	18 (450)	24 (600)	30 (750)	36 (900)	42 (1050)	48 (1200)	60 (1500)
Average Pipe I.D. in (mm)	12.2 (310)	15.1 (384)	18.2 (462)	24.1 (612)	30.2 (767)	36.0 (914)	42.0 (1067)	47.9 (1217)	59.9 (1521)
Average Pipe O.D. in (mm)	14.5 (368)	17.7 (450)	21.4 (544)	28.0 (711)	35.5 (902)	41.5 (1054)	47.4 (1204)	54.1 (1374)	67.1 (1704)
Minimum Pipe Stiffness * @ 5% Deflection #/in./in. (kN/m <sup>2</sup> )	75 (517)	60 (414)	56 (386)	50 (345)	46 (317)	40 (276)	35 (241)	35 (241)	30 (207)

\*Minimum pipe stiffness values listed; contact a representative for average values.

## ADS SANITITE® HP 12”- 60” PIPE SPECIFICATION

### Scope

This specification describes 12- through 60-inch (300 to 1500 mm) ADS SaniTite HP pipe for use in gravity-flow sanitary sewer applications.

### Pipe Requirements

ADS 12”-30” (300 to 750mm) SaniTite HP dual wall pipe shall have a smooth interior and annular exterior corrugations; 30”-60” (750 to 1500mm) SaniTite HP triple wall pipe shall have a smooth interior and exterior surfaces with annular inner corrugations.

- 12- through 30-inch (300 to 750 mm) dual wall pipe shall meet ASTM F2764
- 30- through 60-inch (750 to 1500 mm) triple wall pipe shall meet ASTM F2764
- 12- through 60-inch (300 to 1500 mm) pipe shall have a minimum pipe stiffness of 46 pii when tested in accordance with ASTM D2412.
- Manning’s “n” value for use in design shall be 0.012.

### Joint Performance

Pipe shall be joined using a bell and spigot joint meeting the requirements of ASTM F2764. The joint shall be watertight according to the requirements of ASTM D3212, with the addition of a 15 psi pressure requirement. Gaskets shall meet the requirements of ASTM F477. Gaskets shall be installed by the pipe manufacturer and covered with a removable, protective wrap to ensure the gaskets are free from debris. A joint lubricant available from the manufacturer shall be used on the gasket and bell during assembly. 12- through 60-inch (300 to 1500 mm) diameters shall have a reinforced bell with a polymer composite band installed by the manufacturer.

### Fittings

Fittings shall conform to ASTM F2764. Bell and spigot connections shall utilize a welded or integral bell and valley or inline gaskets meeting the watertight joint performance requirements of ASTM D3212.

### Field Pipe and Joint Performance

To assure watertightness, field performance verification may be accomplished by testing in accordance with ASTM F1417 or ASTM F2487. Appropriate safety precautions must be used when field-testing any pipe material. Contact the manufacturer for recommended leakage rates.

### Material Properties

Polypropylene compound for pipe and fitting production shall be an impact modified copolymer meeting the material requirements of ASTM F2764.

### Installation

Installation shall be in accordance with ASTM D2321 and ADS recommended installation guidelines, with the exception that minimum cover in traffic areas for 12- through 48-inch (300 to 1200 mm) diameters shall be one foot (0.3 m) and for 60-inch (1500mm) diameter the minimum cover shall be 2-ft (0.6m) in single run applications. Backfill for minimum cover situations shall consist of Class 1 (compacted) or Class 2 (minimum 90% SPD) material. Maximum fill heights depend on embedment material and compaction level; please refer to Technical Note 2.05. Contact your local ADS representative or visit our website at [www.ads-pipe.com](http://www.ads-pipe.com) for a copy of the latest installation guidelines.

### Pipe Dimensions

Nominal Pipe I.D. in (mm)	12 (300)	15 (375)	18 (450)	21 (535)	24 (600)	30 (750)	36 (900)	42 (1050)	48 (1200)	60 (1500)
Average Pipe I.D. in (mm)	12.1 (307)	14.9 (378)	18.0 (457)	21.1 (536)	24.1 (612)	30.1 (765)	35.7 (907)	41.8 (1062)	47.3 (1201)	59.3 (1506)
Average Pipe O.D. in (mm)	14.5 (368)	17.6 (447)	21.2 (538)	24.8 (629)	28.0 (711)	35.5 (902)	41.5 (1054)	47.4 (1199)	54.1 (1374)	67.1 (1705)

**\*OD values listed above are NOT for manhole connector sizing. See ADS Standard Detail 205A-F for the recommended manhole connector based on product and diameter.**

## ADS HPXR 75 PIPE SPECIFICATION

### Scope

This specification describes 30- through 60-inch (750 to 1500 mm) ADS HPXR 75 pipe for use in gravity-flow storm sewer and sanitary sewer applications.

### Pipe Requirements

ADS 30"-60" HPXR 75 pipe shall have a smooth interior and exterior surfaces with annular inner corrugations.

- 30- through 60-inch (750 to 1500 mm) pipe shall meet ASTM F2764, Type T.
- 30- through 60-inch (750 to 1500 mm) pipe shall have a minimum pipe stiffness of 75 pii when tested in accordance with ASTM D2412.
- Manning's "n" value for use in design shall be 0.012.

### Joint Performance

Pipe shall be joined with a gasketed integral bell & spigot joint meeting the requirements of ASTM F2764. 30- through 60-inch (750 to 1500 mm) shall be watertight according to the requirements of ASTM D3212, with the addition of a 15psi pressure requirement. Spigot shall have two gaskets meeting the requirements of ASTM F477. Gaskets shall be installed by the pipe manufacturer and covered with a removable, protective wrap to ensure the gaskets are free from debris. A joint lubricant available from the manufacturer shall be used on the gasket and bell during assembly. 30- through 60-inch (750 to 1500 mm) diameters shall have bells reinforced with fiberglass composite wrap installed by the manufacturer.

### Fittings

Fittings shall conform to ASTM F2764. Bell and spigot connections shall utilize a welded or integral bell and valley or inline gaskets meeting the watertight joint performance requirements of ASTM D3212.

### Field Pipe and Joint Performance

To assure watertightness, field performance verification may be accomplished by testing in accordance with ASTM F1417 or ASTM F2487. Appropriate safety precautions must be used when field-testing any pipe material. Contact the manufacturer for recommended leakage rates.

### Material Properties

Polypropylene compound for pipe and fitting production shall meet the material requirements of ASTM F2764. Fiberglass used in the external wrap shall be E type glass meeting ASTM D578.

### Installation

Installation shall be in accordance with ASTM D2321 and ADS recommended installation guidelines, with the exception that minimum cover in traffic areas for 30- through 48-inch (750 to 1200 mm) diameters shall be one foot (0.3 m) and for 60-inch (1500mm) diameters the minimum cover shall be 2-ft (0.6m) in single run applications. Backfill for minimum cover situations shall consist of Class 1, Class 2 (minimum 90% SPD) or Class 3 (minimum 95% SPD) material. Maximum fill heights depend on embedment material and compaction level; please refer to Technical Note 2.09. Contact your local ADS representative or visit our website at [www.ads-pipe.com](http://www.ads-pipe.com) for a copy of the latest installation guidelines.

### Pipe Dimensions

Pipe I.D. in (mm)	30 (750)	36 (900)	42 (1050)	48 (1200)	60 (1500)
Pipe O.D.* in (mm)	35.7 (907)	41.7 (1059)	47.6 (1209)	54.5 (1384)	67.4 (1712)

\*Pipe O.D. values are provided for reference purposes only, values stated for 24 through 60-inch are ±1 inch. Contact a sales representative for exact values

## ADS N-12<sup>®</sup> LOW HEAD PIPE SPECIFICATION

### Scope

This specification describes 24- through 60-inch (600 to 1500 mm) ADS N-12 Low Head pipe for use in low head / low pressure applications.

### Pipe Requirements

N-12 Low Head pipe shall have a smooth interior and annular exterior corrugations.

- 24- through 60-inch (600 to 1500 mm) pipe shall meet AASHTO M294, Type S or ASTM F2306 with the modifications listed herein.
- Manning's "n" value for use in design shall be 0.012.
- Where low head applications sustain continuous pressure, the sustained pressure shall not exceed 5psi and the surge pressure shall not exceed 10 psi.

### Joint Performance

Pipe shall be joined using a bell and spigot joint meeting the requirements of AASHTO M294 or ASTM F2306. The joint shall be watertight according to the requirements of ASTM D3212. Gaskets shall meet the requirements of ASTM F477. Gaskets shall be installed by the pipe manufacturer and covered with a removable, protective wrap to ensure the gaskets are free from debris. A joint lubricant available from the manufacturer shall be used on the gasket and bell during assembly. 12- through 60-inch (300 to 1500 mm) diameters shall have a reinforced bell with a polymer composite band installed by the manufacturer.

### Fittings

Fittings shall conform to AASHTO M294 or ASTM F2306. Bell and spigot connections shall utilize a welded or integral bell and inline, valley, or saddle gaskets meeting the watertight joint performance requirements of ASTM D3212.

### Field Pipe and Joint Performance

To assure watertightness, field performance verification may be accomplished by testing in accordance with ASTM F1417 or ASTM F2487. Appropriate safety precautions must be used when field-testing any pipe material. Contact the manufacturer for recommended leakage rates.

### Material Properties

Virgin material for pipe and fitting production shall be high-density polyethylene conforming with the minimum requirements of cell classification 435400C for the corrugated exterior profile, and 445464C, for the interior liner as defined and described in the latest version of ASTM D3350, except that carbon black content should not exceed 4%. The 24- through 60-inch (600 to 1500mm) virgin pipe material shall comply with the notched constant ligament-stress (NCLS) test as specified in Sections 9.4 and 5.1 of AASHTO M294 and ASTM F2306 respectively. The interior liner resin shall have a material designation code of PE3408/PE3608 by the Plastic Pipe Institute and a Hydrostatic Design Basis of 1600 psi.

### Installation

Installation shall be in accordance with ASTM D2321 and ADS recommended installation guidelines, with the exceptions that minimum cover in traffic areas for 24- through 48-inch (600 to 1200mm) diameters shall be one foot (0.3m) and for 60-inch (1500mm) diameter the minimum cover shall be 2-feet (0.6m) in single run applications. Backfill for minimum cover situations shall consist of Class 1 (compacted) or Class 2 (minimum 90% SPD) material. Maximum fill heights depend on embedment material and compaction level; please refer to Technical Note 2.01. Contact your local ADS representative or visit our website at [www.ads-pipe.com](http://www.ads-pipe.com) for a copy of the installation guidelines.

### Pipe Dimensions

Pipe I.D. in (mm)	24 (600)	30 (750)	36 (900)	42 (1050)	48 (1200)	60 (1500)
Pipe O.D.* in (mm)	27.8 (719)	36 (914)	42 (1067)	48 (1219)	54 (1372)	67 (1702)
Minimum Pipe Stiffness @ 5% Deflection #/in./in. (kN/m <sup>2</sup> )	28 (195)	28 (195)	22 (150)	20 (140)	18 (125)	14 (95)

\*Pipe O.D. values are provided for reference purposes only, values stated for 24 through 60-inch are ±1 inch. Contact a sales representative for exact values

## ADS SINGLE WALL HEAVY DUTY PIPE SPECIFICATION

### Scope

This specification describes 3- through 24-inch (75 to 600 mm) ADS single wall high density corrugated polyethylene heavy duty pipe for use in gravity-flow land drainage applications.

### Pipe Requirements

ADS single wall high density corrugated polyethylene heavy duty pipe shall have annular interior and exterior corrugations.

- 3- through 24-inch (75 to 600 mm) pipe shall meet ASTM F667.

### Joint Performance

Joints for 3- to 24- inch (75 – 600 mm) shall be made with split or snap couplings. Standard connections shall meet the requirements of the ASTM F667. Gasketed connections shall incorporate a closed-cell synthetic expanded rubber gasket meeting the requirements of ASTM D1056 Grade 2A2. Gaskets, when applicable, shall be installed by the pipe manufacturer.

### Fittings

Fittings shall conform to ASTM F667.

### Material Properties

Pipe and fitting material shall be high density polyethylene conforming with the minimum requirements of cell classification 323410C or 333410C as defined and described in the latest version of ASTM D3350.

### Installation

Installation shall be in accordance with ASTM D2321 and ADS recommended installation guidelines, with the exception that minimum cover in trafficked areas for 3- through 24-inch (75 to 600 mm) diameters shall be one foot (0.3 m). Maximum fill heights depend on embedment material and compaction level; please refer to Technical Note 2.03. Contact your local ADS representative or visit our website at [www.ads-pipe.com](http://www.ads-pipe.com) for a copy of the installation guidelines.

### Pipe Dimensions

	Nominal Diameter, in (mm)									
Pipe I.D. in (mm)	3 (75)	4 (100)	5 (125)	6 (150)	8 (200)	10 (250)	12 (300)	15 (375)	18 (450)	24 (600)
Pipe O.D.* in (mm)	3.6 (91)	4.6 (117)	5.8 (147)	7.0 (178)	9.5 (241)	12.0 (305)	14.5 (368)	18.0 (457)	22.0 (559)	28.0 (711)

\*Pipe O.D. values are provided for reference purposes only, values stated for 12 through 24-inch are ±1 inch. Contact a sales representative for exact values

\*\*All diameters available with or without perforations.

## ADS SINGLE WALL HIGHWAY PIPE SPECIFICATION

### Scope

This specification describes 3- through 24-inch (75 to 600 mm) single wall high density corrugated polyethylene highway pipe, for use in gravity-flow land drainage applications.

### Pipe Requirements

ADS single wall high density corrugated polyethylene highway pipe shall have annular interior and exterior corrugations.

- 3- through 10-inch (75 to 250 mm) pipe shall meet AASHTO M252, Type C or CP.
- 12- through 24-inch (300 to 600 mm) pipe shall meet AASHTO M294, Type C or CP.

### Joint Performance

Joints for 3- to 24- inch (75 – 600 mm) shall be made with split or snap couplings. Standard connection shall meet the soil-tightness requirements of AASHTO M252 or M294. Gasketed connections shall incorporate a closed-cell synthetic expanded rubber gasket meeting the requirements of ASTM D1056 Grade 2A2. Gaskets, when applicable, shall be installed by the pipe manufacturer.

### Fittings

Fittings shall conform to AASHTO M252 or AASHTO M294.

### Material Properties

Pipe and fittings shall be made of virgin polyethylene compounds that comply with the cell classification 424420C for 4- through 10-inch (100 to 250mm) diameters, or 435400C for 12- through 24-inch (300 to 600mm) diameters, as defined and described in ASTM D3350, except that carbon black content should not exceed 4%. The 12- through 24-inch (300 to 600mm) virgin pipe material shall comply with the notched constant ligament-stress (NCLS) test as specified in Sections 9.5 of AASHTO M294.

### Installation

Installation shall be in accordance with ASTM D2321 and ADS recommended installation guidelines with the exception that minimum cover in trafficked areas for 3- through 24-inch (75 to 600 mm) diameters shall be one foot (0.3 m). Maximum fill heights depend on embedment material and compaction level; please refer to Technical Note 2.03. Contact your local ADS representative or visit our website at [www.ads-pipe.com](http://www.ads-pipe.com) for a copy of the latest installation guidelines.

### Pipe Dimensions

	Nominal Diameter, in (mm)									
Pipe I.D. in (mm)	3 (75)	4 (100)	5 (125)	6 (150)	8 (200)	10 (250)	12 (300)	15 (375)	18 (450)	24 (600)
Pipe O.D.* in (mm)	3.6 (91)	4.6 (117)	5.8 (147)	7.0 (178)	9.5 (241)	12.0 (305)	14.5 (368)	18.0 (457)	22.0 (559)	28.0 (711)

\*Pipe O.D. values are provided for reference purposes only, values stated for 12 through 24-inch are  $\pm 1$  inch. Contact a sales representative for exact values

\*\*All diameters available with or without perforations.

## ADS GRAIN-AIRE® PIPE SPECIFICATION

### Scope

This specification describes 12- through 36-inch (300 to 900 mm) ADS Grain-Aire pipe for use in metering air and providing uniform flow air in flat storage structures.

### Pipe Requirements

ADS Grain-Aire pipe shall have a smooth interior and annular exterior corrugations covered with a polypropylene protective screen to provide unrestricted air flow.

### Joint Performance

Pipe shall be joined with split or snap couplers covering at least two full corrugations on each end of the pipe.

### Material Properties

Pipe and fittings shall be high density polyethylene conforming with the minimum requirements of cell classification 424400C as defined and described in the latest version of ASTM D3350.

### Perforations

Nominal Diameter	Corrugations Per Foot	Number of Holes Per Foot	Min. Hole Diameter	Open Area Per Foot
12"	6.3	36	7/16"	5.4
15"	4.7	24	5/8"	7.36
18"	4.7	24	5/8"	7.36
24"	4.7	24	5/8"	7.36
30"	2.9	32	1/2"	6.28
36"	2.4	32	1/2"	6.28

### Protective Screen

Material	Polypropylene	
Bursting Strength (lbs/in <sup>2</sup> )	484	ASTM D3786
Weight (oz/yd <sup>2</sup> )	5.3	ASTM D3776
% Open Area	25	ASTM D475
Tensile Strength (lbs) (Grab Test)	425 (Wrap)	ASTM D5034
	273 (Fill)	



## ADS ADVANEDGE® PIPE SPECIFICATION

### Scope

This specification describes 12- and 18-inch (300 and 450 mm) ADS AdvanEDGE oblong corrugated pipe for use in subsurface drainage applications.

### Product Requirements

ADS AdvanEDGE shall have annular interior and exterior corrugations.

- 12- and 18-inch (300 to 450 mm) shall meet ASTM D7001.

ADS AdvanEDGE outside dimensions shall be 1.5" thick by 12.5" wide or 1.5" thick by 18.5" wide. AdvanEDGE shall have internal bracing adjoining each long wall to prevent crushing under typical loading. AdvanEDGE shall be made available with or without an external geotextile wrap.

### Material Properties

All pipe and fittings shall be made of polyethylene with a minimum cell classification of 424420C as defined and described in the latest version of ASTM D3350.

### Perforations

Nominal Pipe Size, in (mm)	12 (300)	18 (450)
Slot Length (avg), in (mm)	1.125 (29)	1.125 (29)
Slot Width (avg), in (mm)	0.125 (3.2)	0.125 (3.2)
Water Inlet Area (approx.), in <sup>2</sup> /ft	15	20

### Filter Fabric

Fabric Properties	Test Method	Minimum Average Roll Values
Grab Tensile Strength (lbs.) (weakest principle direction)	ASTM D4632	120
Grab Elongation (%) (weakest principle direction)	ASTM D4632	60
Trapezoidal Tear (lbs.) (weakest principle direction)	ASTM D4533	40
Puncture (lbs.)	ASTMD4833	30
Permittivity (sec <sup>-1</sup> )	ASTM D4491	0.7
AOS (U.S. Sieve Size)	ASTM D4751	60
U.V. Resistance	ASTM D4355	70

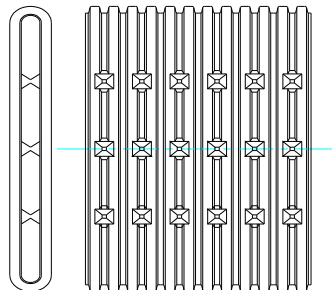

## ADS SB2® PIPE SPECIFICATION

### Scope

This specification describes ADS SB2 pipe available in 8- and 10-inch (200 and 250 mm) diameters for use in on-site waste disposal applications.

### Pipe Requirements

ADS SB2 pipe shall have a corrugated interior and corrugated exterior a pre-installed septic fabric.

- 8- and 10-inch (200 and 250 mm) pipe shall meet the requirements of ASTM F667.
- There shall be two ½ inch (12.7 mm) holes 120 degrees apart on the length of the pipe.
- The 8-inch (200 mm) and 10-inch (250mm) pipe shall have 1.0 square inches per foot of open area.

### Joint Performance

Pipe shall be joined with internal or external snap couplers covering at least two full corrugations on each end of the pipe.

### Fittings

Fittings shall conform to ASTM F667.

### Material Properties

Pipe material shall be high density polyethylene conforming with the minimum requirements of cell classification 424410C as defined and described in the latest version of ASTM D3350; or ASTM D1248 Type III, Class C, Category 4, Grade P33.

### Filter Fabric Properties

Material	Nylon (100%)
Fabric	Spun Bond
Fiber Size (denier per filament)	5
Weight (ounces per yd <sup>2</sup> , ASTM D3776)	0.85
Burst Strength (pounds per in <sup>2</sup> , ASTM D3786)	28
Air Permeability (CFM per ft <sup>2</sup> , ASTM D737)	650
Equivalent Opening Size (Army Corps of Engineers, W 02215)	50
Water Flow Rate (gal/min/ft <sup>2</sup> , ASTM D4491)	163
Melt Temperature (ASTM D3786)	218° C (425° F)

### Installation

Installation shall be in accordance with ADS recommended installation instructions and those issued by a local health department. For leachfield applications, installation shall be in accordance with ASTM F481 and as regulated by regional, state, and local agencies. Proper authorization for specific applications and designs should be obtained prior to installation to ensure suitability in certain locales. Contact your local ADS representative or visit our website at [www.ads-pipe.com](http://www.ads-pipe.com) for a copy of the installation guidelines.

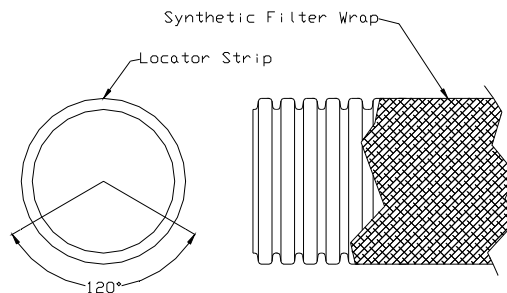

## ADS 3000 TRIPLEWALL® PIPE SPECIFICATION

### Scope

This specification describes 3- and 4-inch (75 and 100 mm) ADS 3000 TripleWall pipe for use in gravity-flow drainage and leach field applications.

### Pipe Requirements

ADS 3000 TripleWall pipe shall have a smooth interior and exterior.

- 3- and 4-inch (75 and 100 mm) pipe shall meet the requirements of ASTM F810.
- Manning's "n" value for use in design shall not be less than 0.009.

### Joint Performance

Pipe joints shall be bell-and-spigot. Bell ends shall be integrally formed on the pipe at one end to form a soil-tight connection.

### Material Properties

Pipe material shall be high-density polyethylene conforming with the minimum requirements of cell classifications 424410C or E as defined and described in the latest version of ASTM D3350. The material formulation shall include recycled polyethylene.

### Installation

For gravity-flow drainage applications, installation shall be in accordance with ASTM D2321 and ADS recommended installation guidelines with the exception that minimum cover in traffic areas shall be one foot (0.3 m). For leachfield applications, installation shall be in accordance with ASTM F481 and as regulated by regional, state, and local agencies. Proper authorization for specific applications and designs should be obtained prior to installation to ensure suitability in certain locales. Contact your local ADS representative or visit our website at [www.ads-pipe.com](http://www.ads-pipe.com) for a copy of the installation guidelines.

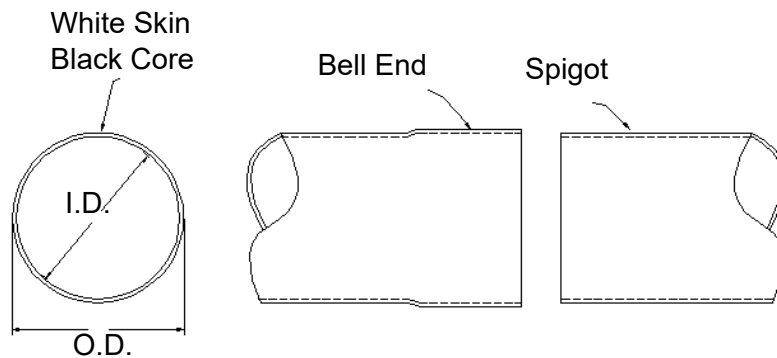

### Perforation Options\*

Nominal Diameter, in (mm)		
Nominal Pipe I.D. in (mm)	3 (75)	4 (100)
Average Pipe I.D. in (mm)	2.875 (73)	3.875 (98.5)
Average Pipe O.D. in (mm)	3.250 (83)	4.215 (107)

\*Perforation sizes are based on customer requirements and availability by region.

\*\*All diameters available with or without perforations

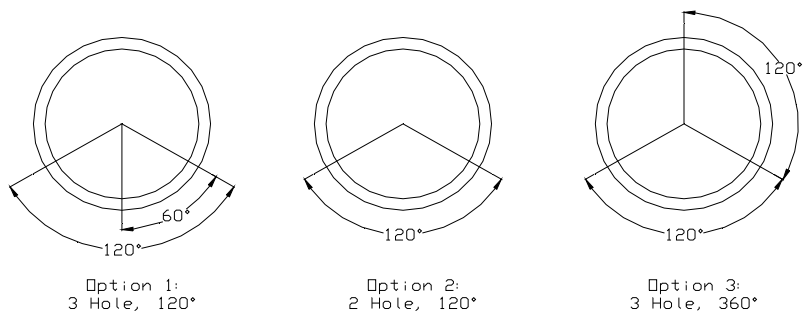

## ADS SMOOTHWALL SEWER & DRAIN PIPE SPECIFICATIONS

### Scope

This specification describes ADS Smoothwall Sewer & Drain pipe in 3- through 6-inch (75 to 150mm) diameters for use in gravity flow drainage and leach field applications.

### Pipe Requirements

ADS Smoothwall Sewer & Drain pipe shall have a smooth interior and exterior.

- 3- through 6-inch (75 to 150mm) pipe shall meet the requirements of ASTM F810.
- Manning's "n" value for use in design shall not be less than 0.009.

### Joint Performance

Pipe joints shall be bell-and-spigot. Bell ends shall be integrally formed on the pipe at one end to form a soil-tight connection.

### Material Properties

Pipe material shall be high-density polyethylene conforming with the minimum requirements of cell classifications 424410C or E as defined and described in the latest version of ASTM D3350. The material formulation shall include recycled polyethylene.

### Installation

For gravity-flow drainage applications, installation shall be in accordance with ASTM D2321 and ADS recommended installation guidelines with the exception that minimum cover in traffic areas shall be one foot (0.3 m). For leachfield applications, installation shall be in accordance with ASTM F481 and as regulated by regional, state, and local agencies. Proper authorization for specific applications and designs should be obtained prior to installation to ensure suitability in certain locales. Contact your local ADS representative or visit our website at [www.ads-pipe.com](http://www.ads-pipe.com) for a copy of the latest installation guidelines.

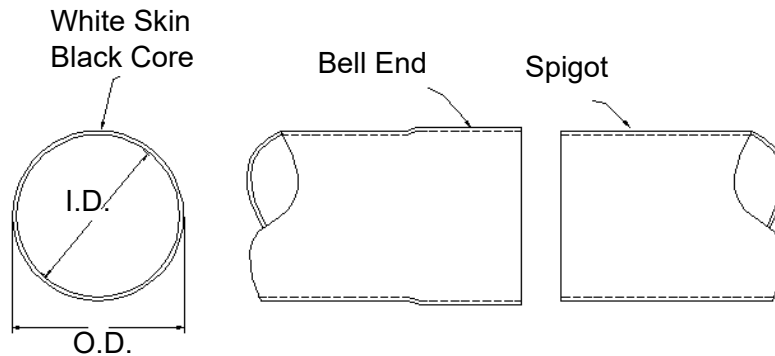

### Perforation Options\*\*

Nominal Diameter, in (mm)			
Nominal Pipe I.D. in (mm)	3 (75)	4 (100)	6 (150)
Average Pipe O.D. in (mm)	3.250 (83)	4.215 (107)	6.275 (159)
SDR Rating*	38	38	43
Pipe Stiffness p <sub>ii</sub> (kPa)	19 (131)	11 (76)	8 (55)

\*Check with a sales representative for availability by region; other SDR rated pipe may be available.

\*\*Perforation sizes are based on customer requirements and availability by region.

\*\*\*All diameters available with or without perforations

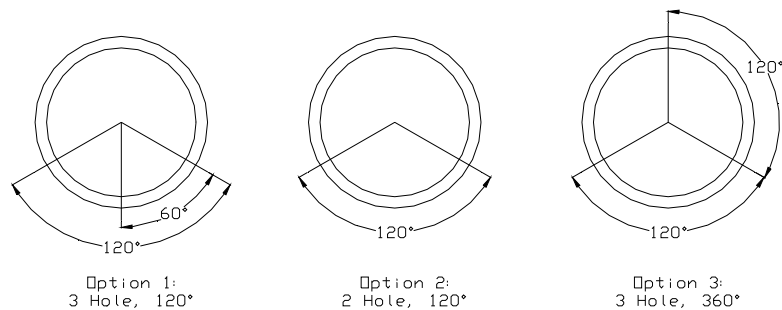

## ADS CHANNEL-FLOW® PIPE SPECIFICATIONS

### Scope

This specification describes ADS Channel-Flow pipe in 4-inch (100 mm) diameter for use in on-site waste applications.

### Pipe Requirements

ADS Channel-Flow pipe shall have a corrugated interior and corrugated exterior.

- 4-inch (100 mm) pipe shall meet the requirements of ASTM F667 and SCS 606.
- Perforations shall be spaced every 4.2-inches (107 mm) on the length of the pipe.

### Joint Performance

Pipe shall be joined with self-coupling stubs located at the ends of each pipe section.

### Fittings

Fittings shall conform to ASTM F667.

### Material Properties

Pipe material shall be high density polyethylene conforming with the minimum requirements of cell classification 424410C as defined and described in the latest version of ASTM D3350; or ASTM D1248 Type III, Class C, Category 4, Grade P33.

### Installation

Installation shall be in accordance with ASTM F481 and those issued by the local health department.

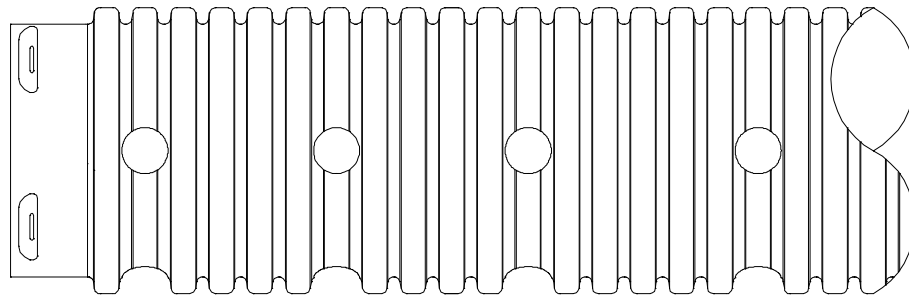

### Perforation Options\*

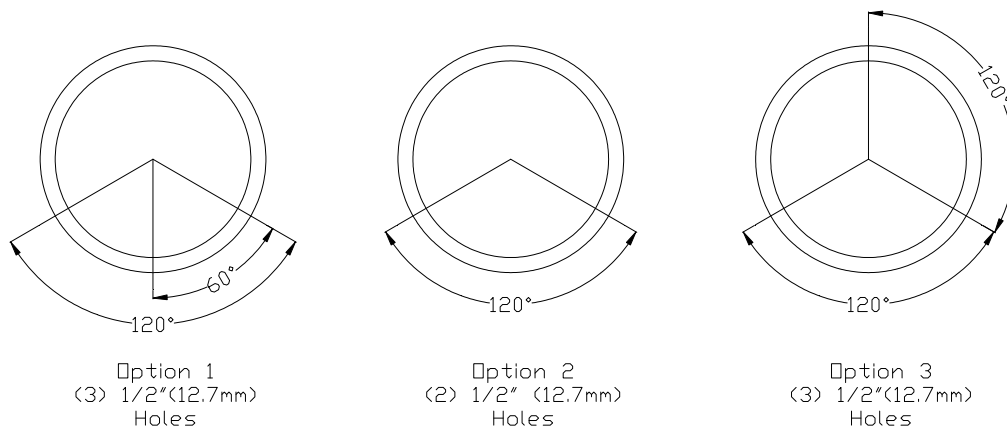

\*Check with sales representative for perforation option availability by region.

## ADS CHANNEL-MUCK PIPE SPECIFICATIONS

### Scope

This specification describes ADS Channel-Muck pipe in 4- through 6-inch (100 to 150mm) diameters for use in agricultural drainage applications.

### Pipe Requirements

ADS Channel-Muck pipe shall have a corrugated interior and corrugated exterior.

- 4- through 6-inch (100 to 150mm) pipe shall meet the requirements of ASTM F667 and SCS 606.
- There shall be three perforations every 4.2-inch (107 mm) on the length of the pipe.

### Joint Performance

Pipe shall be joined with self-coupling stubs located at the ends of each pipe section.

### Fittings

Fittings shall conform to ASTM F667.

### Material Properties

Pipe material shall be high density polyethylene conforming with the minimum requirements of cell classification 424410C as defined and described in the latest version of ASTM D3350; or ASTM D1248 Type III, Class C, Category 4, Grade P33.

### Installation

Installation shall be in accordance with ADS recommended installation instructions and those issued by regional, state or local agencies.

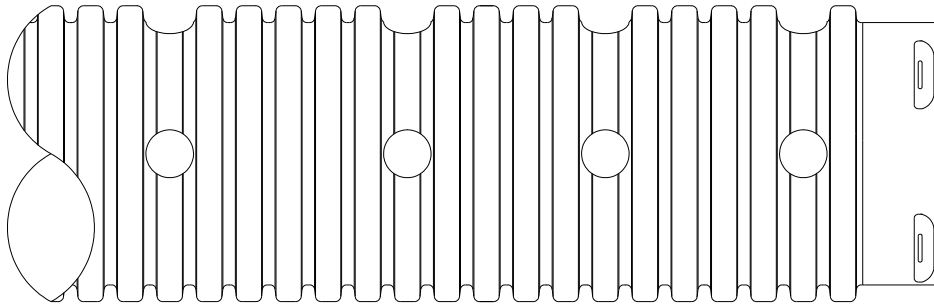

### Perforation Options\*

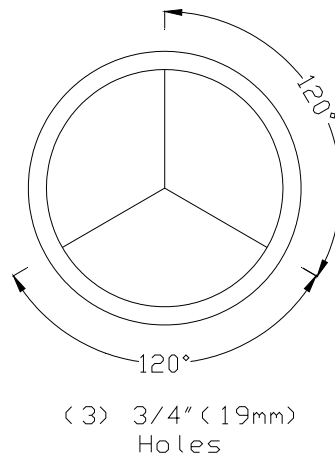

\* Check with sales representative for perforation option availability by region.

## ADS DURASLOT® PIPE SPECIFICATION

### Scope

This specification describes 4- through 36-inch (100 to 900 mm) ADS DURASLOT pipe for use in surface drain applications.

### Pipe Requirements

DURASLOT pipe, as manufactured and distributed by ADS, Inc., shall have a smooth interior and annular exterior corrugations with an aluminum slot grate frame mounted longitudinally along the length of the pipe to accept the grate while maintaining the original pipe diameter.

- 4- through 10-inch (100 to 250mm) pipe shall meet AASHTO M252, Type S.
- 12- through 36-inch (300 to 900 mm) pipe shall meet AASHTO M294, Type S or ASTM F2306.
- Manning's "n" value for use in design shall be 0.012.

The aluminum slot grate frame shall be manufactured from 0.063" tempered commercial aluminum meeting the requirements of ASTM B209, consisting of two parallel plates separated by spacers spanning the slot on 6" centers. The grate shall be ½ - #13 galvanized steel. The grate shall have a diamond-shaped opening and be ADA compliant. The flange at the bottom of the aluminum slot grate frame shall be riveted to the pipe with a minimum of two rivets per linear foot.

### Fittings

DURASLOT fittings shall be modified from fittings which conform to AASHTO M252, AASHTO M294, or ASTM F2306.

### Installation

Installation shall be in accordance with ADS recommended installation instructions. Contact your local ADS representative or visit [www.ads-pipe.com](http://www.ads-pipe.com) for a copy of the latest installation guidelines.

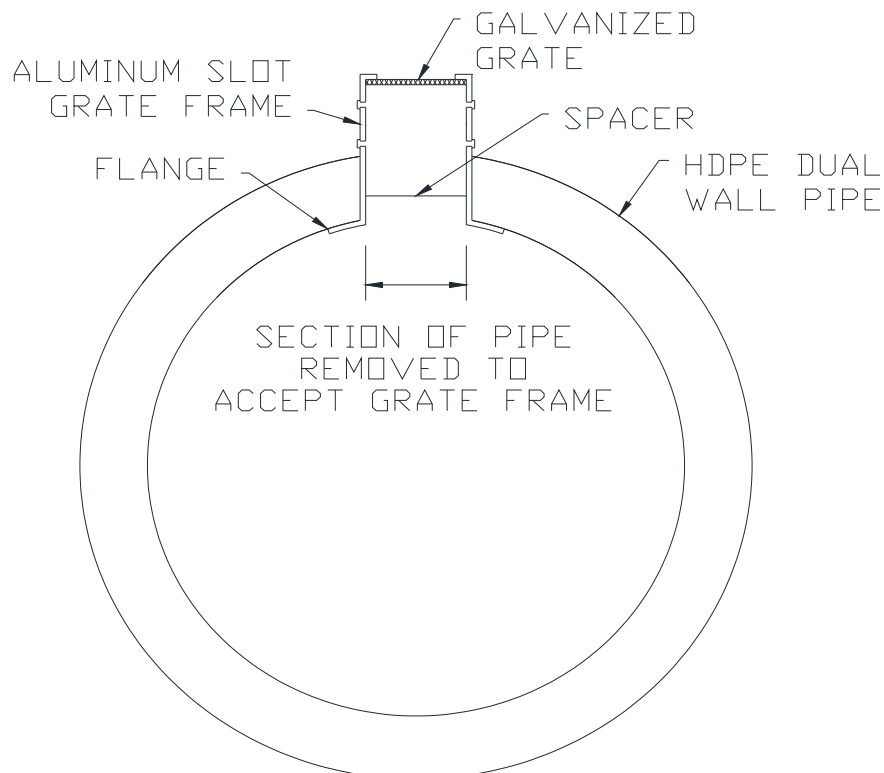



**ADS DURASLOT® STANDARD DIMENSIONS**

	Nominal Pipe Diameter									
	4"	6"	8"	10"	12"	15"	18"	24"	30"	36"
<b>L</b> (Drain Grate Length)	118"				116"					
<b>E</b> (Pipe End Length)	1"				2"					
<b>H</b> (2.5" slot)	2.75"	3"	3"	3"	3.5"	3.75"	4"	4.75"	5"	5.25"
<b>H</b> (6.0" slot)	6.25"	6.5"	6.5"	6.5"	7"	7"	7"	7.25"	8.25"	8.25"
<b>W</b> (Pipe Width w/ Corrugation)	0.34"	0.46"	0.61"	0.73"	1.15"	1.30"	1.57"	1.86"	2.55"	2.85"
<b>F</b> (Flange Length)	0.5"	0.75"	0.75"	0.75"	0.75"	0.75"	0.75"	1.0"	1.0"	1.0"
<b>O</b> (Opening Width)	1.25"	1.75"	1.75"	1.75"	1.75"	1.75"	1.75"	1.75"	1.75"	1.75"
<b>S</b> (Slot Width)	1.75"	2.25"	2.25"	2.25"	2.25"	2.25"	2.25"	2.25"	2.25"	2.25"

Note:

1. Variable and custom slot heights upon request. Production of variable and custom slots will require approval by engineering services and fabrication. Signed shop drawings also required from interested party.
2. Other grate material options upon request. Contact local ADS representative for availability of grate material option.

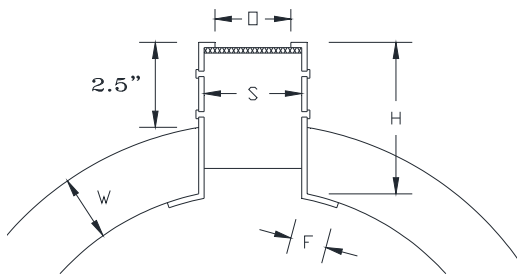
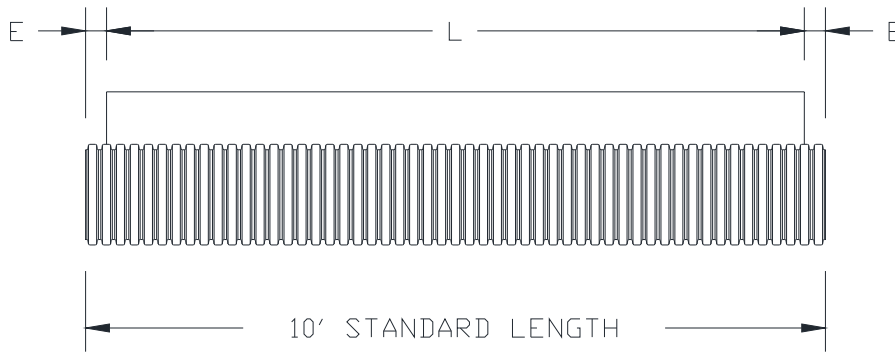

4" – 10"

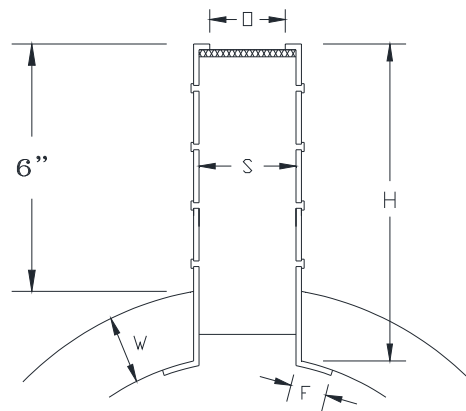

12" – 36"

## ADS POST TENSIONING DUCT SPECIFICATION

### Scope

This specification describes 2-inch (50 mm) ADS Post Tensioning Duct for use in tension cable shield applications.

### Pipe Requirements

ADS Post Tensioning Duct shall have spiral corrugated interior and exterior corrugations. Minimum inside diameter and average outer diameter shall be 1.91-inches and 2.3-inches respectively. Average pipe stiffness at 5% deflection shall be 80pii when tested in accordance with ASTM D2412. Average weight shall be 0.19 pounds per foot.

### Joint Performance

Pipe shall be joined with an external coupler covering at least two full corrugations on each end of the pipe. Standard (non-gasketed) connections shall meet the soil-tightness requirements of AASHTO M252.

### Material Properties

Pipe and fitting material shall be high density polyethylene conforming with the minimum requirements of cell classification 435400C as defined and described in the latest version of ASTM D3350.

### Installation

Installation shall be in accordance with state or local regulations and those issued by the design engineer.

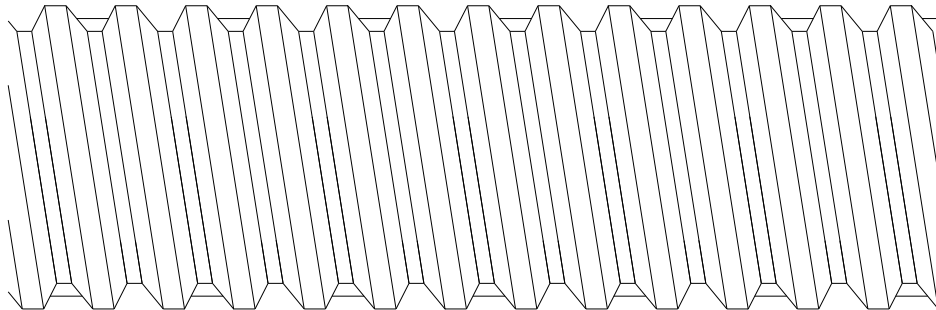

## ADS TURF-FLOW PIPE SPECIFICATION

### Scope

This specification describes 2-inch (50 mm) ADS Turf-Flow Pipe for use in recreational turf drainage applications.

### Pipe Requirements

ADS Turf-Flow shall have spiral corrugated interior and exterior corrugations. Minimum inside diameter and average outer diameter shall be 1.91-inches and 2.3-inches respectively. Average pipe stiffness at 5% deflection shall be 50 pii when tested in accordance with ASTM D2412. Average weight shall be 0.13 pounds per foot. The material formulation shall include recycled polyethylene.

### Joint Performance

Pipe shall be joined with an external coupler covering at least two full corrugations on each end of the pipe. Standard (non gasketed) connections shall meet the soil-tightness requirements of AASHTO M252.

### Material Properties

Pipe and fitting material shall be high-density polyethylene conforming with the minimum requirements of cell classification 424410C as defined and described in the latest version of ASTM D3350.

### Installation

Installation shall be in accordance with state or local regulations and those issued by the design engineer.

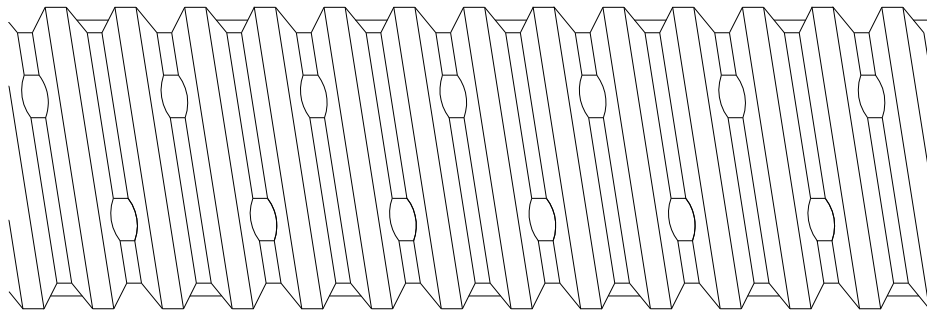

### Perforations

Perforation Type	Narrow Slots	Wide Slots
Slot Length (Max), in. (mm)	0.75 (19)	0.75 (19)
Slot Width (Max), in. (mm)	0.015 (.38)	0.19 (4.8)
Water Inlet Area (Min), in <sup>2</sup> /ft (cm <sup>2</sup> /m) *	0.11 (2.3)	1.34 (28.3)

\* Minimum value recommended for design purposes. Actual perforation inlet area may be greater.

### Hydraulic Data

Recommended Design Manning's "n"	0.017
Conveyance Number**, k	0.23

\*\* Flow Rate, Q (cfs) = (Conveyance Number, k) \* (Slope)<sup>1/2</sup>  
See Hydraulics section of the Drainage Handbook for additional

information

## ADS INJECTION MOLDED FITTING SPECIFICATION

### Scope

This specification describes 4- through 12-inch (100 to 300 mm) ADS Injection Molded Fittings for use in joining gravity-flow drainage and sewer pipe. Available fittings include tees, wyes, bends, couplers, and reducing fittings.

### Fitting Requirements

ADS Injection Molded Fittings shall have a smooth interior and exterior.

- 4- through 10-inch (100 to 250mm) shall meet the fitting requirements of AASHTO M252.
- 12-inch (300mm) shall meet AASHTO M294 or ASTM F2306.

### Joint Performance

The fittings shall provide a joint meeting AASHTO M252, AASHTO M294 or ASTM F2306. For non-gasketed fittings, dimples in the bell shall engage the corrugation to provide a soil-tight connection. For gasketed fittings, the joint shall be watertight according to the requirements of ASTM D3212. Gaskets shall be made of EPDM meeting the requirements of ASTM F477. Gaskets shall be supplied by the pipe manufacturer. A joint lubricant supplied by the manufacturer shall be used on the gasket and bell during assembly.

### Material Properties

Virgin material for fitting production shall be high density polyethylene conforming with the minimum requirements of cell classification 314420C or 314420E for 4- through 12-inch (100 to 300mm) diameters, as defined and described in the latest version of ASTM D3350, except that carbon black content should not exceed 4%.

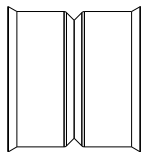

SIZE-ON-SIZE OR REDUCING  
BELL-BELL COUPLER

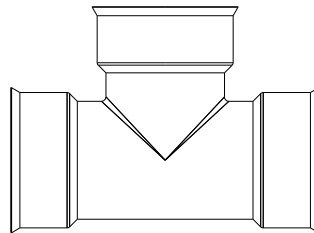

SIZE-ON-SIZE OR REDUCING TEE

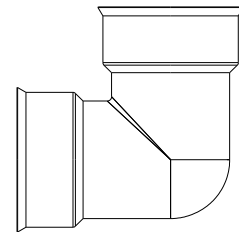

90-DEG BEND

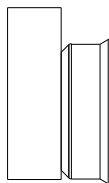

SPIGOT-BELL REDUCER

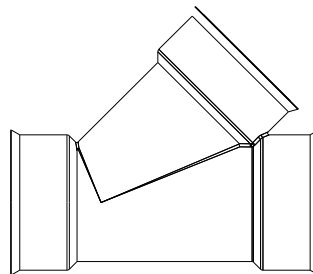

SIZE-ON-SIZE OR REDUCING  
45-DEG WYE

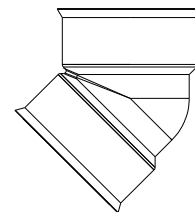

45-DEG BEND

*Refer to the Product Catalog for a complete listing of available fittings. Availability may vary for each fitting type based on diameter or joint performance.*

### INJECTION MOLDED FITTINGS JOINT SYSTEM

(Joint configuration & availability subject to change without notice. Product detail may differ slightly from actual product appearance.)

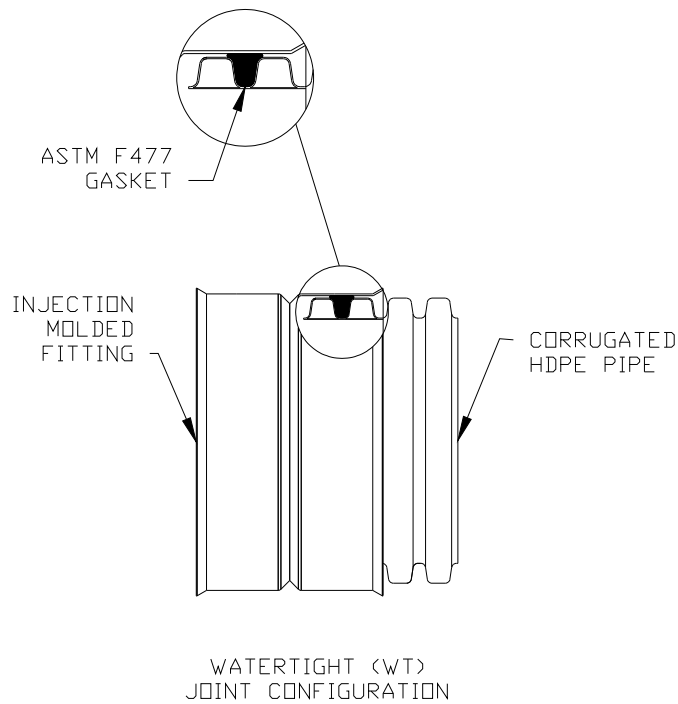
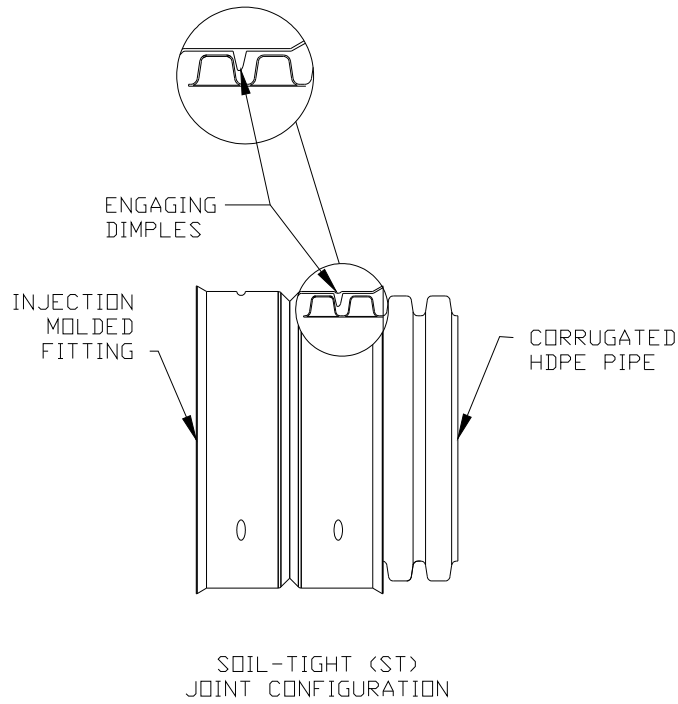

## MAR MAC® POLYSEAL REPAIR COUPLER SPECIFICATION

### Scope

The Mar Mac Polyseal Repair Coupler is a connection for 8- through 60-inch (200 to 1500 mm) ADS N-12 pipe.

### Material Properties

The Mar Mac Coupler, as manufactured by Mar Mac® Construction Products, Inc. and distributed by ADS, Inc., consists of a mastic adhesive base layer, a cross-laminated polyethylene middle layer and a spun-bonded geotextile polypropylene cloth outer layer.

### Installation

Installation shall be in accordance with Mar Mac Construction Products, Inc. recommended installation instructions. Polyseal repair coupler, in conjunction with corrugated HDPE pipe, is considered a soil-tight connection unless otherwise approved by local governing body.

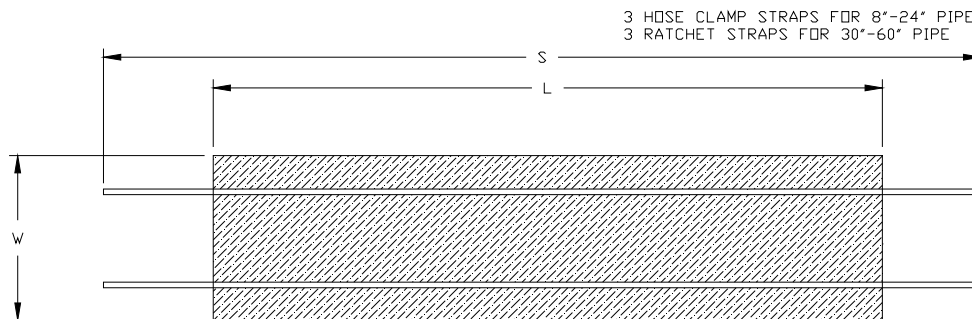

Nominal Pipe Diameter*, in. (mm)	Strap Length (S) in. (mm)	Standard		Double Wide	
		Length (L) in. (mm)	Width (W) in. (mm)	Length (L) in. (mm)	Width (W) in. (mm)
8 (200)	40 (1016)	35 (889)	4 (101)	n/a	n/a
10 (250)	40 (1016)	42 (1067)	6 (152)	n/a	n/a
12 (300)	50 (1270)	52 (1321)	7 (178)	52 (1321)	12 (305)
15 (375)	58 (1473)	62 (1575)	10 (254)	62 (1575)	14 (355)
18 (450)	71 (1803)	75 (1905)	10 (254)	75 (1905)	16 (406)
24 (600)	93 (2362)	94 (2387)	12 (305)	94 (2387)	20 (508)
30 (750)	125 (3175)	125 (3175)	15 (381)	125 (3175)	24 (609)
36 (900)	141 (3581)	141 (3581)	18 (457)	141 (3581)	30 (762)
42 (1050)	161 (4089)	161 (4089)	20 (508)	161 (4089)	30 (762)
48 (1200)	183 (4648)	183 (4648)	20 (508)	183 (4648)	32 (813)
60 (1500)	219 (5562)	222 (5639)	28 (711)	222 (5639)	46 (1168)

\*4", 6" and 54" standard couplers may be available by special order. Contact an ADS representative.

## ADS PVC COUPLING SPECIFICATION

### Scope

This specification describes the PVC Coupling for use in joint repair of surface drainage applications.

### Requirements

PVC couplings are manufactured from SDR 35 Sewer PVC pipe stock.

All PVC couplings shall be manufactured to meet the mechanical property requirement for fabricated fittings as described in ASTM D3034 and F679.

### Joint Performance

Joints created by the PVC coupler shall be manufactured with a bell coupling sized to accept dual wall corrugated HDPE pipe with a rubber gasket. A joint lubricant supplied by the manufacturer shall be used on the gasket and bell during assembly. Gaskets supplied with the coupling shall meet the requirements of ASTM F477.

The joint shall be watertight according to the laboratory requirements of ASTM D3212. Joints shall remain watertight when subjected to a 1.5 degree axial misalignment.

### Material Properties

PVC coupling shall be manufactured from SDR 35 Sewer PVC pipe stock meeting ASTM D3034 for 4- through 15-inch diameters or F679 for 18- through 24-inch diameters.

### Installation

Installation shall be in accordance with ADS pipe installation instructions using typical flexible pipe installation methods. Contact your local ADS representative or visit [www.ads-pipe.com](http://www.ads-pipe.com) for latest installation instructions.

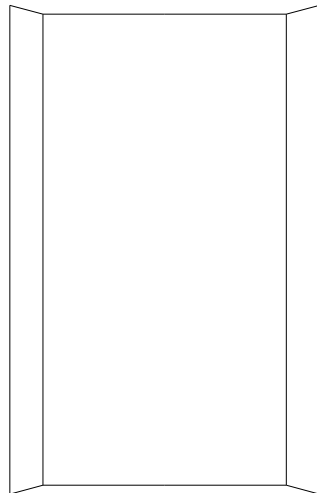



## ADS WATERSTOP™ GASKET SPECIFICATION

### Scope

This specification describes the ADS WaterStop gasket available in 12- to 60- inch (300 to 1500 mm) diameters and used for a field installed seal that prevents water infiltration or exfiltration at manhole connections.

### Material Properties

The ADS WaterStop gasket is made of a polyisoprene compound which meets the physical property requirements of ASTM C923.

### Installation

Installation shall be in accordance with ADS recommended installation instructions. Contact your local ADS representative or visit [www.ads-pipe.com](http://www.ads-pipe.com) for a copy of the latest installation guidelines.

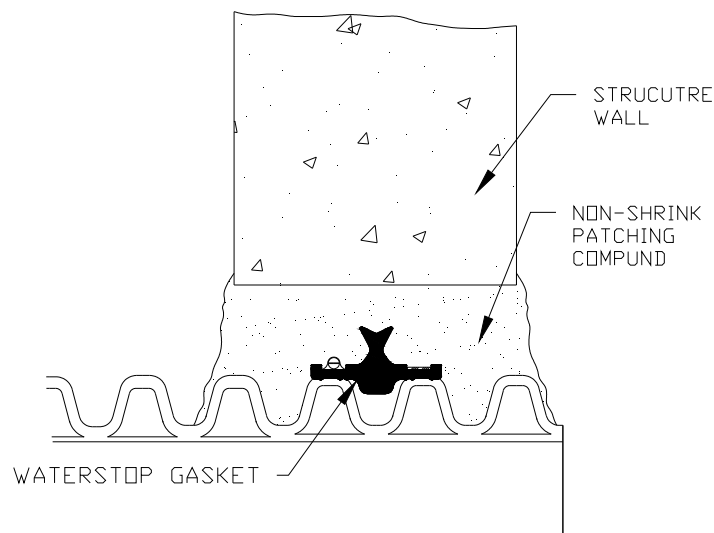

Nominal Pipe I.D., in.	Recommended Minimum Hole Diameter, in.	Minimum Distance Pipe Invert to Structure Invert, in
12	19.5	3.7
15	23	4
18	26.5	4.2
24	33.3	4.5
30	40.5	5.2
36	47	5.5
42	53	5.7
48	59	5.7
54*	65	6.4
60	72	6.4

\* Check with Sales Representative for availability

## ADS FLARED END SECTION SPECIFICATION

### Scope

This specification describes 12- through 36-inch (300 to 900mm) ADS Flared End Sections for use in culvert and drainage outlet applications.

### Requirements

The ADS Flared End Section shall be high density polyethylene meeting ASTM D3350 minimum cell classification 213320C; contact manufacturer for additional cell classification information. When provided, the metal threaded fastening rod shall be stainless steel.

### Installation

Installation shall be in accordance with ADS installation instructions and with those issued by state or local authorities. Contact your local ADS representative or visit [www.ads-pipe.com](http://www.ads-pipe.com) for the latest installation instructions.

	PIPE DIAMETER, in (mm)					
Diameter in (mm)	12 (300)	15 (375)	18 (450)	24 (600)	30 (750)	36 (900)
A in (mm)	6.5 (165)	6.5 (165)	7.5 (191)	7.5 (191)	7.5 (191)	7.5 (191)
B (max) in (mm)	10.0 (254)	10.0 (254)	15.0 (381)	18.0 (475)	22.0 (559)	25.0 (635)
H in (mm)	6.5 (165)	6.5 (165)	6.5 (165)	6.5 (165)	8.6 (218)	8.6 (218)
L in (mm)	25.0 (635)	25.0 (635)	32.0 (813)	36.0 (914)	58.0 (1473)	58.0 (1473)
W in (mm)	29.0 (737)	29.0 (737)	35.0 (889)	45.0 (1143)	63.0 (1600)	63.0 (1600)

\*Product detail may differ slightly from actual product appearance

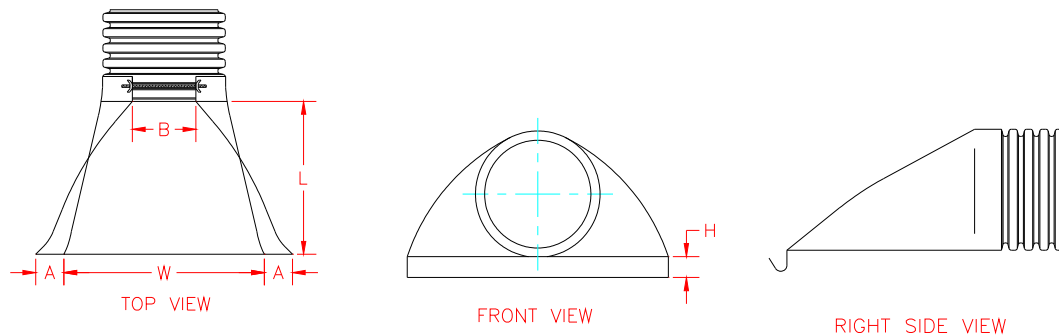

## ADS MITERED END SECTION SPECIFICATION

### Scope

This specification describes 12- through 60-inch (300 to 1500mm) Mitered End Sections for use in culvert and drainage outlet applications.

### Requirements

The invert of the pipe and the end section shall be at the same elevation. Mitered End Section shall be high-density polyethylene conforming with the minimum requirements of cell classification 335400C as defined and described in ASTM D3350 except that carbon black content should not exceed 4%. The 12- through 60-inch (300 to 1500mm) virgin pipe material shall comply with the notched constant ligament-stress (NCLS) test as specified in Sections 9.5 and 5.1 of AASHTO M294 and ASTM F2306 respectively.

### Installation

Installation shall be in accordance with ASTM D2321 and ADS installation guidelines. Contact your local ADS representative or visit our website at [www.ads-pipe.com](http://www.ads-pipe.com) for a copy of the installation guidelines.

Nominal Dimensions										
Pipe Dia. (in)	Slope x:1		Slope 2:1		Slope 3:1		Slope 4:1		Slope 6:1	
	C* (in)	D (in)	B (in)	OAL (in)	B (in)	OAL (in)	B (in)	OAL (in)	B (in)	OAL (in)
12	3	3	12	20	18	26	24	32	36	44
15	4	4	14.8	24.5	22	31.9	29.4	39.1	41.6	51.4
18	4.2	4	21	33	30	42	39	51	60	72
24	6	6	24	40	36	52	48	64	72	88
30	6	6	36	52	56	72	72	88	108	124
36	6.9	6	48.1	64.6	73.9	92.3	96.9	115.4		
42	5.2	6	64.4	82	93.6	111.3	122.9	140.5		
48	5.4	6	76.1	93.6	111.2	128.7	146.4	163.9		
54	5.4	6	85.1	108.4						
60	3.6	6	100.6	123.9						

\*The "C" dimension varies slightly for some diameters depending on the slope

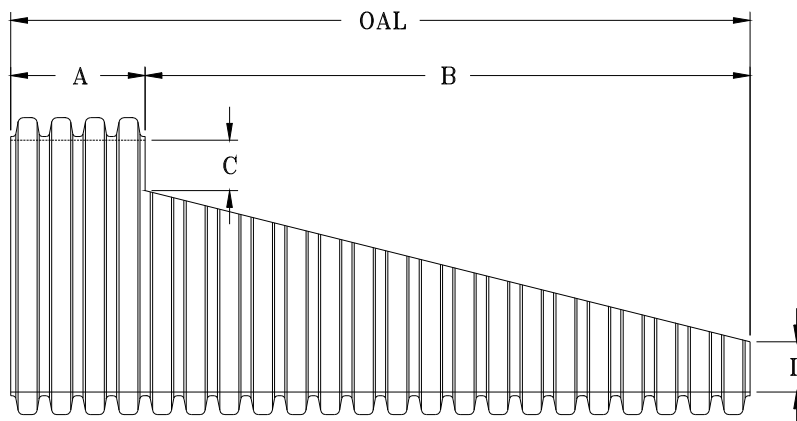

Note: ADS recommends that the product be installed with a concrete collar/edge to support and close corrugations per DOT specifications. The Channel at the bottom of the taper must be shaped to prevent toe lift by the inlet water flow.

## ADS TAYLOR END PLUG PRODUCT SPECIFICATION

### Scope

This specification describes 4- through 60-inch (100 to 1500mm) ADS End Plugs, as manufactured by Taylor Made Plastics, Inc., for use in temporary storm drainage, gravity-flow applications.

### Requirements

End Plug shall be made of polyethylene with a gasket sized in order to fit in the spigot end of corrugated polyethylene pipe.

### Joint Performance

The end plug shall provide a soil-tight joint per ASTM F2306.

### Installation

Installation shall be in accordance with Taylor Made Plastics, Inc installation instructions. End plugs are not intended for permanent use or vertical applications.

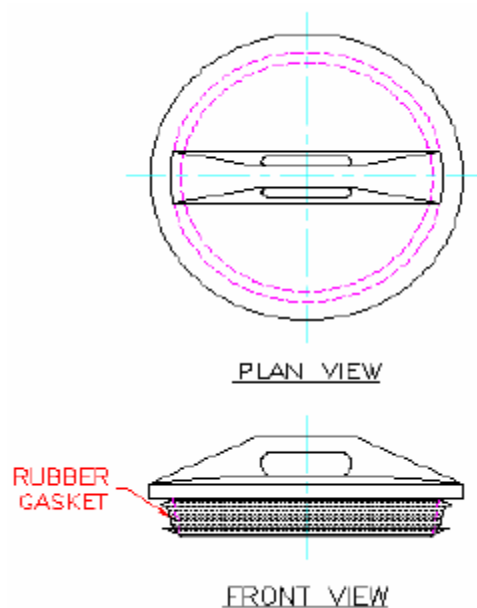

## ADS STORM WATER QUALITY UNIT PRODUCT SPECIFICATION

### Scope

This specification describes 36- through 60-inch (900 to 1500 mm) Storm Water Quality Units for use in on-site point source storm water treatment applications.

### Requirements

Storm Water Quality Units shall have a smooth interior and annular exterior corrugations meeting the requirements of ASTM F2737.

The unit shall have at least three containment zones, each zone separated from the next by use of a weir or baffle plate

Weir and baffle plates shall be welded at all interfaces between the plate and water quality unit. First weir plate shall incorporate a saw tooth design and shall be reinforced with stiffeners positioned horizontally on the downstream side of the plate to be retained.

Storm Water Quality Units shall provide adequate clean-out and inspection access.

### Joint Performance

Connections for the bypass line and the unit shall utilize the same joint quality as specified for the main storm sewer pipe. Couplers for the bypass line may be either split couplers, in-line bell couplers, snap couplers, bell-bell couplers, or welded bell couplers.

### Material Properties

Virgin material for pipe and fittings used to produce Storm Water Quality Units shall be high density polyethylene conforming with the minimum requirements of cell classification 424420C for 4- through 10-inch (100 to 250 mm) diameters, and 435400C for 12- through 60-inch (300 to 1500mm) diameters as defined and described in the latest version of ASTM D3350. The virgin pipe material shall be evaluated using the notched constant ligament-stress (NCLS) test as specified in Sections 9.5 and 5.1 of AASHTO M294 and ASTM F2306, respectively. All smooth baffle and weir plates shall be high density polyethylene.

### Installation

Installation shall be in accordance with the ADS recommended installation guidelines, utilizing a class I (ASTM D2321) structural backfill material or flowable fill (CLSM –Controlled Low Strength Material). Contact your local ADS representative or visit [www.ads-pipe.com](http://www.ads-pipe.com) for the latest installation instructions.

### Performance

Water Quality Units shall remove a minimum of 80% of the first flush total suspended solids (TSS) based on flow rates and corresponding sieve sizes shown in Table 1. Water Quality units shall be installed “offline” to prevent re-suspension of solids in high flow situations. Offline installation shall be constructed utilizing an ADS By-Pass structure. Flow through the unit shall be controlled by an orifice fabricated on the outlet end of the structure.

**Table 1: Storm Water Quality Unit Dimensions and Specifications (based on mathematical calculations)**

I.D. (in)	Inlet Size (in)	Outlet Size (in)	Length (ft)	Treated Flow Rate (cfs)	Sediment Volume (ft <sup>3</sup> )	Floatables Volume (ft <sup>3</sup> )	Sieve Size
36	10	10	20	1.50	65	30	140
	10	10	40	2.38	137	63	140
	10	10	20	0.70	65	30	200
	10	10	40	1.60	137	63	200
42	12	12	20	1.73	83	38	140
	12	12	40	3.66	175	81	140
	12	12	20	0.86	83	38	200
	12	12	40	1.83	175	81	200
48	12	12	20	2.26	116	55	140
	12	12	40	3.94	245	115	140
	12	12	20	1.13	116	55	200
	12	12	40	2.39	245	115	200
60	15	15	20	2.95	183	87	140
	15	15	40	6.23	385	184	140
	15	15	20	1.47	183	87	200
	15	15	40	3.12	385	184	200

**ADS STORM WATER QUALITY UNIT**

*(Unit configuration & availability subject to change without notice. Product detail may differ slightly from actual product appearance.)*

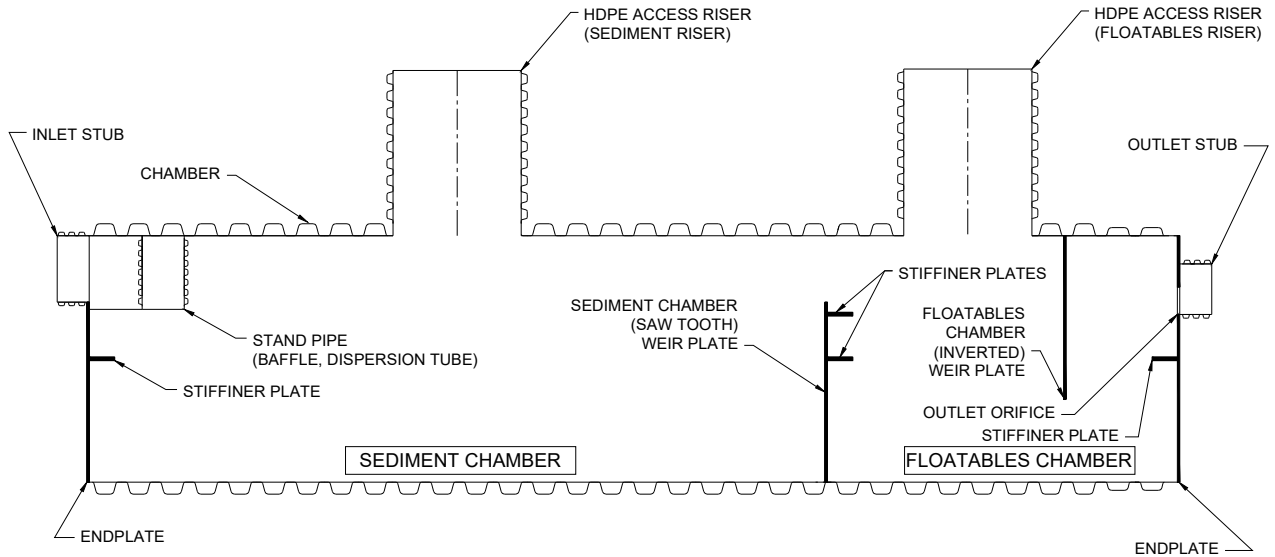

## ADS GREASE INTERCEPTOR PRODUCT SPECIFICATION

### Scope

This specification describes the 750-, 1000-, and 1500-gallon ADS Grease Interceptor for on-site use trapping floatable grease and oils in water treatment applications.

### Requirements

Grease Interceptors shall meet requirements specified in ASTM F2649. Grease Interceptors shall have a smooth interior and annular exterior corrugations using pipe that meets AASHTO M252 Type S, AASHTO M294 Type S, or ASTM F2306. The inlet and outlet of the unit shall utilize 8-inch SDR 32.5 HDPE pipe. A weir plate shall be installed with an orifice centrally located to control flow into the last chamber. At the weir plate, a vertical half-round pipe shall be installed to minimize contaminants through the orifice.

### Joint Performance

Connections to the inlet and outlet shall utilize couplers with the same joint performance as the main sewer pipe.

### Material Properties

Virgin material for pipe and fittings used to produce the Grease Interceptor shall be high density polyethylene conforming with the minimum requirements of cell classification 424420C for 4- through 10-inch (100- to 250-mm) diameters, and 435400C for 12- through 60-inch diameters as defined and described in the latest version of ASTM D3350. The virgin pipe material shall be evaluated using the notched constant ligament-stress (NCLS) test as specified in Sections 9.5 and 5.1 of AASHTO M294 and ASTM F2306, respectively.

### Installation

Installation shall be in accordance with the ADS recommended installation guidelines, utilizing a class I (ASTM D2321) structural backfill material or flowable fill (CLSM –Controlled Low Strength Material). Contact your local ADS representative or visit [www.ads-pipe.com](http://www.ads-pipe.com) for the latest installation instructions.

**Grease Interceptor Dimensions and Specifications**

Volume (gal)	Chamber Diameter (in)	Inlet Diameter (in)	Outlet Diameter (in)	A	B	C	D	E	F	G
750	48	8	8	131"	31"	100"	35.7"	33.7"	88"	41.7"
1000	48	8	8	173.25"	31"	142"	35.7"	33.7"	116"	41.7"
1500	60	8	8	156"	31"	123"	35.7"	47.5"	105"	53.5"

*(Unit configuration & availability subject to change without notice. Product detail may differ slightly from actual product appearance.)*

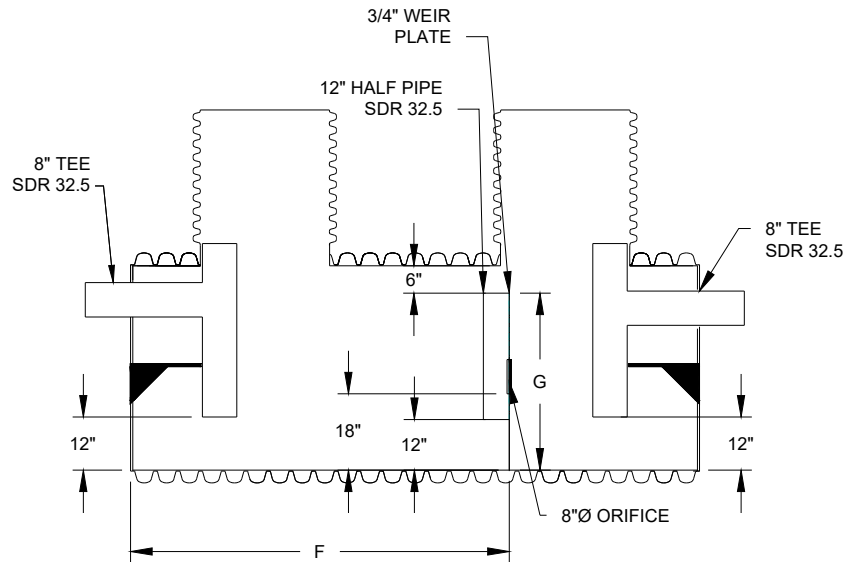
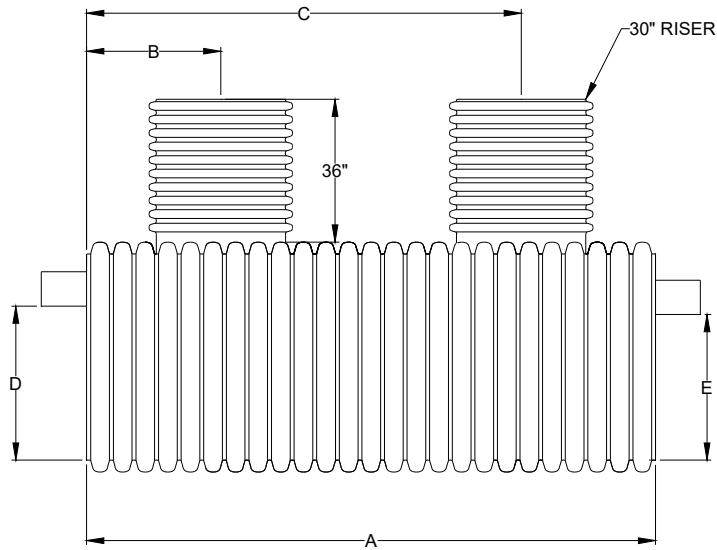



## ADS BIODIFFUSER™ SEPTIC LEACHING CHAMBER SPECIFICATION

### Scope

This specification describes the Standard, High-Capacity, Bio 2, and Bio 3 BioDiffuser units for use in onsite wastewater disposal applications.

### Chamber Requirements

BioDiffuser chambers are manufactured from high-density polyethylene with an open bottom, solid top and louvered sidewalls. Sidewall louvers shall be designed to minimize soil intrusion.

Chamber shall meet the load rating of H-10 (16,000 lb per axle) with a minimum of 12-inches (0.3m) of cover when tested in accordance with IAPMO PS 63 and installed in accordance with ADS installation procedures.

The 16" high capacity chamber is also available in H-20 (32,000 lb per axle) rated version. To order the H-20 ARC chamber model, please contact an ADS representative.

### Chamber Connection

Each chamber shall interlock with the beginning of the next chamber by overlapping post and dome while engaging overlapping flanges.

### Material Properties

Each chamber shall be manufactured from high density polyethylene resin as defined and described in IAPMO PS 63.

### Installation

Installation shall be in accordance with ADS installation procedures and those issued by the local health department regulations.

### Chamber Dimensions

	11" Standard Model No. 1100BD	16" High Capacity Model No. 1600BD	Bio 2 (15" Narrow) Model No. 1500BD	Bio 3 (22" Narrow) Model No. 2200BD
Length (A)	76"	76"	87"	87"
Repeat Length (E)	75"	75"	86"	86"
Side Wall Height (B)	6.4"	11.2"	9.0"	9.0"
Overall Height (C)	11"	16"	12"	12"
Overall Width (D)	34"	34"	15"	22"
Capacity	9.2 cu ft (68.8 gal)	13.6 cu ft (101.7 gal)	5.0 cu ft (37.4 gal)	8.5 cu ft (63.6 gal)
Weight	27 lbs	35 lbs	19 lbs	28 lbs
Units/Pallet	27	45	90	70
Truck Load Quantity*	39 pallets	18 pallets	14 pallets	14 pallets

\*End Caps may reduce truck load pallet quantity.

(Unit configuration & availability subject to change without notice. Product detail may differ slightly from actual product appearance.)

**11" Standard Chamber**

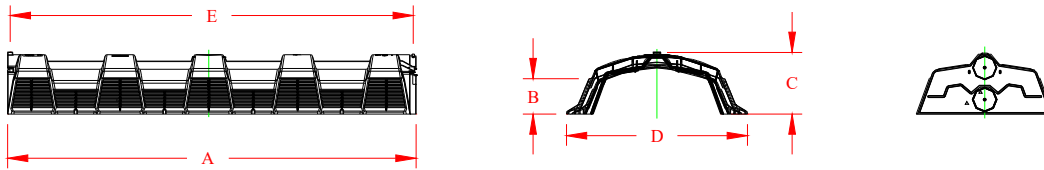

**16" High Capacity Chamber**

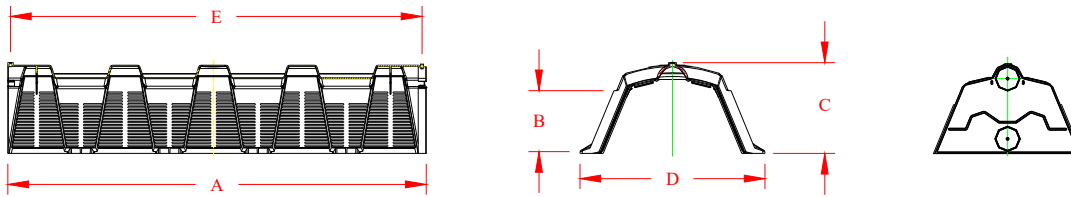

**Bio 2 (15" Narrow) Chamber**

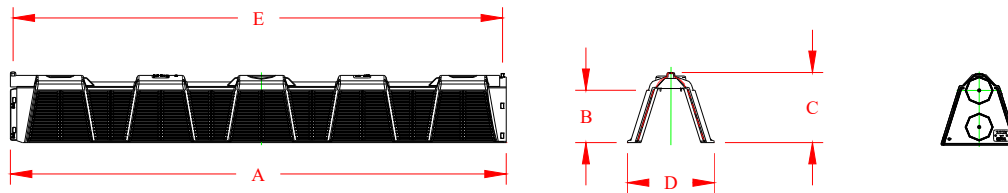

**Bio 3 (22" Narrow) Chamber**

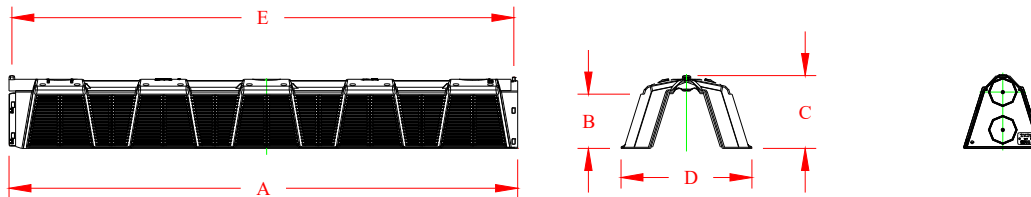

## ADS ARC™ SEPTIC LEACHING CHAMBER SPECIFICATIONS

### Scope

This specification describes the Arc chamber units for use in onsite wastewater disposal applications.

### Chamber Requirements

Arc chambers are manufactured from high-density polyethylene with an open bottom, solid top and louvered sidewalls. Sidewall louvers shall be designed to minimize soil intrusion.

Chamber shall meet the load rating of H-10 (16,000 lb per axle) with a minimum of 12 inches of cover when tested in accordance with IAPMO PS 63 and installed in accordance with manufacturers installation procedures.

### Chamber Connection

Each chamber shall interlock with an integral articulating joint. Articulating joints shall have a free range of horizontal rotation of 20 degrees, with a maximum of 10 degrees in either direction. Articulating joint shall be constructed by placing the dome with engaging knuckle of the incoming chamber over the post end of the previously-installed chamber.

### Material Properties

Each chamber shall be manufactured from high-density polyethylene as defined and described in IAPMO PS 63.

### Installation

Installation shall be in accordance with ADS installation procedures as well as all state and local health department regulations.

	Arc 18	Arc 24	Arc 36	Arc 36 HC	Arc 36 LP
Length (A)	67 in	67 in	63 in	63 in	63 in
Repeat Length (E)	60 in	60 in	60 in	60 in	60 in
Side Wall Height (B)	7.7 in	7.5 in	7.13 in	10.75 in	5.5 in
Overall Height (C)	12 in	12 in	13 in	16 in	8 in
Overall Width (D)	16 in	22.5 in	34 in	34 in	34 in
Capacity	3.42 cu ft (25.6 gal)	5.02 cu ft (37.5 gal)	8 cu ft (60.1 gal)	10.7 cu ft (80 gal)	5.80 cu ft (43.4 gal)
Pallet Quantity	135 chambers	120 chambers	70 chambers	60 chambers	60 chambers
Truck Load Quantity*	16 pallets	16 Pallets	24 Pallets	24 Pallets	24 Pallets

\*End Caps may reduce truck load pallet quantity.

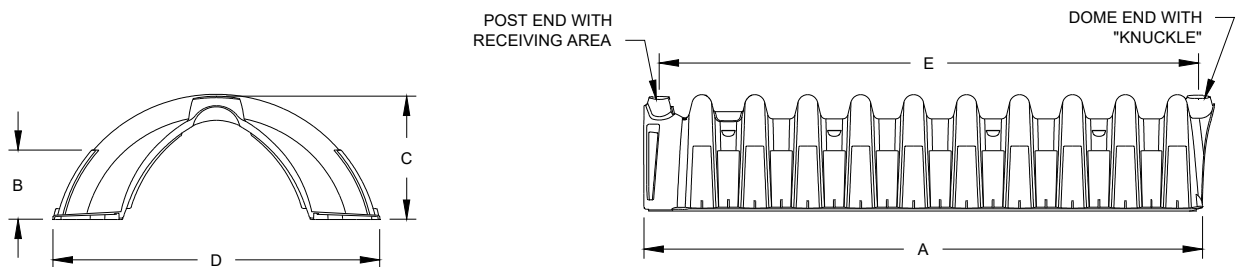

## ADS SUMP PUMP WELL SPECIFICATION

### Scope

This specification describes the ADS sump pump well for use in residential drainage applications.

### Requirements

The sump pump well shall be available in both 14-gallon (53 liters) and 19-gallon (72 liters) sizes. Each well shall have three pre-formed inlet collars sized to fit 4-inch (100mm) corrugated polyethylene drainage lines. Each well shall have a molded side panel designed to accept the outside basement perimeter line at any elevation along the well wall. Both wells shall have a twist-locking lid.

### Material Properties

Sump pump well material shall be high density polyethylene.

### Installation

Installation shall be in accordance with ADS installation instructions and those issued by regional, state, or local agencies.

	A	B	C	D	E	F	G	H	I	J
14-gallon 53 liters	12" 305mm	8" 203mm	14.25" 362mm	4.75" 121mm	20.38" 518mm	18.13" 460mm	24" 610mm	20.88" 530mm	18.38" 467mm	20.5" 521mm
19-gallon 72 liters	12" 305mm	13" 330mm	14.25" 362mm	4.75" 121mm	20.38" 518mm	24" 610mm	31.75" 806mm	20.88" 530mm	18.38" 467mm	20.5" 521mm

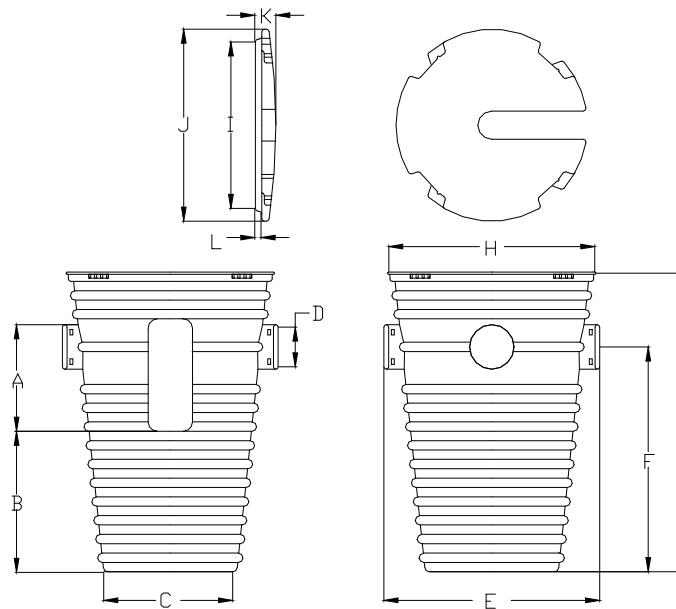

## ADS RADON DUAL PURPOSE VENTED SUMP SPECIFICATION

### Scope

This specification describes the ADS Radon Dual Purpose Vented Sump System for use in residential drainage and ventilation of toxic or noxious gas applications.

### Requirements

The Radon Dual Purpose Vented Sump shall be available in 14-gallon (53 liter) capacity. The sump well shall have three pre-formed inlet collars sized to fit 4-inch (100 mm) corrugated polyethylene drainage lines. Each well shall have a molded side panel designed to accept the outside basement perimeter line at any elevation along the well wall. The lid shall be pre-drilled to accept 1¼-inch (32mm), 1½-inch (38mm), 2 inch (50mm), or 3-inch (75mm) vent and discharge pipes. Rubber o-rings for these pipes, as well as rubber pump wire plug shall be included with the lid kit.

### Material Properties

Radon Dual Purpose Vented Sump shall be high density polyethylene.

### Installation

Installation shall be in accordance with ADS installation instructions and those issued by regional, state, or local agencies.

	A	B	C	D	E	F	G	H
14-gallon 53 liter	12" 305mm	8" 203mm	14.25" 362mm	4.75" 121mm	20.38" 518mm	18.13" 460mm	24" 610mm	20.06" 510mm

### Items Included With Lid Kit

#### Qty.

- 1 Gasket for 4" Sch 40 or SDR 35 PVC inlet line
- 1 Gasket for 2" and 3" Sch 40 PVC vent pipe
- 1 Gaskets for 2", 1 ½", and 1 ¼" Sch 40 PVC pump discharge pipes
- 1 Electrical Cord Stopper
- 1 1" Adhesive Foam Tape

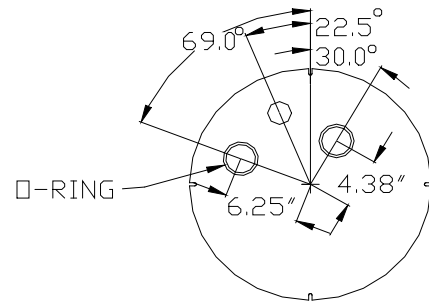

### Items Needed For Lid Kit (Sold Separately)

#### Qty.

- 4 Hex Head Lag Screws ¼" x 1 ½" (minimum)
- 4 Flat Washers ¼"
- 4 Concrete Floor Anchors

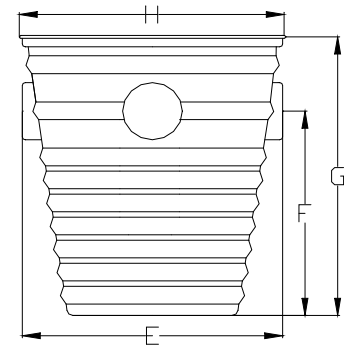
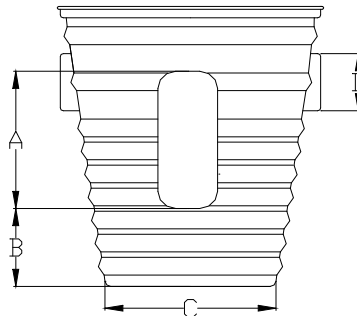

## ADS SEWAGE EJECTOR SUMP SPECIFICATION

### Scope

This specification describes the ADS Sewage Ejector Sump System for use in residential sewage applications.

### Requirements

The Sewage Ejector Sump shall be available in 19-gallon (72 liter) capacity. The sump well shall have one pre-drilled inlet hole with an o-ring gasket adapter for standard 4-inch (100mm) SDR 35 sewer pipe or a PVC hub for standard 4-inch (100mm) schedule 40 sewer pipe. Each well shall have three molded side panels designed to accept an extra inlet line at 90-degree increments around its circumference. The lid shall be pre-drilled to accept 1¼-inch (32mm), 1½-inch (38mm), 2-inch (50mm) or 3-inch (75mm) vent and discharge pipes. Rubber o-rings for these pipes, as well as rubber pump wire plug shall be included in the lid kit.

### Material Properties

Sewage Ejector Sump shall be high-density polyethylene.

### Installation

Installation shall be in accordance with ADS installation instructions and those issued by regional, state, or local agencies.

	A	B	C	D	E	F	G	H
19-gallon 72 liter	12" 305mm	13" 330mm	14.25" 362mm	4.75" 121mm	20.38" 518mm	24" 610mm	31.75" 806mm	20.06" 510mm

### Items Included With Lid Kit

#### Qty.

- 1 Gasket for 4" Sch 40 or SDR 35 PVC inlet line
- 1 Gasket for 2" and 3" Sch 40 PVC vent pipe
- 1 Gaskets for 2", 1 ½", and 1 ¼" Sch 40 PVC pump discharge pipes
- 1 Electrical Cord Stopper
- 1 1" Adhesive Foam Tape

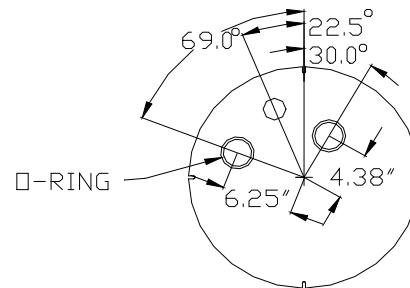

### Items Needed For Lid Kit (Sold Separately)

#### Qty.

- 4 Hex Head Lag Screws ¼" x 1 ½" (minimum)
- 4 Flat Washers ¼"
- 4 Concrete Floor Anchors

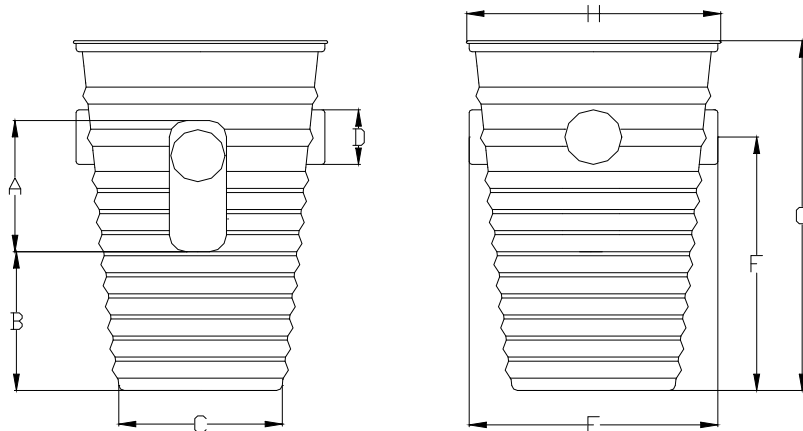

## ADS METER PIT SPECIFICATION

### Scope

This specification describes 18-, 21-, and 24-inch (450, 525, and 600mm) Meter Pit for use as meter enclosures.

### Requirements

ADS Meter Pits shall be white in color. Meter pits shall have a smooth interior and annular exterior corrugations. Based on ASTM D 2412 at 5% deflection the pipe stiffness for 18-inch (450 mm), 21-inch (525 mm), and 24-inch (600 mm) Meter Pits shall be 40 pii (275 N/m/mm), 34 pii (235 N/m/mm), and 34 pii (235 N/m/mm) respectively. The pits shall be available in 24, 30, 36, 48 inch, and 12 foot (0.6, 0.8, 0.9, 1.2, and 3.7 m) lengths. Meter Pits shall be notched at 0 and 180 degrees at the base to accommodate inlet and outlet pipes.

### Material Properties

Meter pits shall be high density polyethylene conforming with the minimum requirements of cell classification 424420 B as defined and described in the latest version of ASTM D3350.

### Installation

Installation shall be in accordance with ADS installation instructions or those issued by regional, state, or local agencies.

### Nominal Dimensions

Inner Diameter	18" 450mm	21" 525mm	24" 600mm
Outer Diameter	21.5" 546mm	25" 635mm	28.4" 721mm

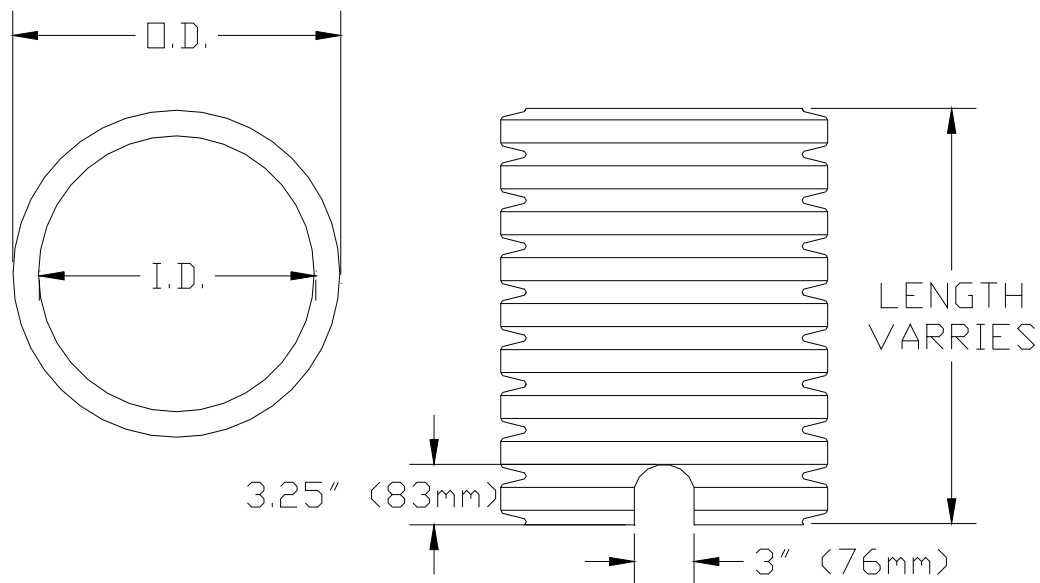

**Warning: This product is not supplied with a grate or lid for means of termination at the ground surface. It is the sole responsibility of the installer/user of this product to adequately insure the product has been covered and secured at the top of the structure/product. Poor installation or failure to adequately cover and secure this product may result in injury to persons and property.**

## ADS FILTER SOCK SPECIFICATION

### Scope

This specification describes 2- through 48-inch (50- to 1200 mm) ADS SOCK synthetic wrap.

### Filter Fabric Requirements

The ADS SOCK shall meet the requirements of ASTM D6707.

ADS sock products as listed on this specification meet Ontario Provincial Standard Specification 1860, Material Specifications for Geotextiles, dated March 1998.

### Filter Fabric Properties

Property	Test Method	
Material	-	Polyester
Fabric	-	Knitted
Permittivity (min.)	ASTM D4491	5.5 sec <sup>-1</sup>
Puncture Resistance (min.)	ASTM D6241	1000 N
AOS (max.)	ASTM D4751	0.600 mm 30 U.S. Sieve
FOS (max.)	CAN/CGSB-148.1, M10-94	450 microns
Mass (relaxed)	ASTM D3887	3.0-3.9 oz/yd <sup>2</sup>
Mass (applied minimum)		2.7-3.5 oz/yd <sup>2</sup>
Thickness (min.)	ASTM D4491	24.0 mils
Permeability (K) (min.)	ASTM D4491	0.390 cm/sec
Burst Strength (min.)	ASTM D3786	760 kpa
Air Permeability (min.)	ASTM D737	700 ft <sup>3</sup> /ft <sup>2</sup> /min
Water Flow Rate (min.)	ASTM D4491 (2" constant head)	300 gal/min/ft <sup>2</sup>
Yarn Denier	-	150
Specific Gravity	-	1.3
Melt Temperature	-	450° F